

TESLA

Wall Connector Application Note: Dynamic Power Management

Overview..... 2
Required Equipment..... 3
Install the Energy Meter.....5
Commission the System.....10
Troubleshooting..... 13
 Energy Meter LED Indication.....13
 TRM not Appearing During Commissioning..... 14
 Negative Site CT Value..... 14
Revision History..... 15



OVERVIEW

As described in the [Wall Connector Installation Manual](#), the Gen 3 Wall Connector should be installed with a circuit breaker for maximum power output (32A). In the event that there is not enough capacity for a breaker in the electrical panel, a smaller breaker can be installed with a lower amperage configuration as follows:

The alternative to a smaller breaker is a costly panel upgrade.

Dynamic Power Management is a new feature that enables Wall Connector to dynamically adjust EV charging power based on live readings of the overall load in the panel. An energy meter is installed to monitor live current in the panel; when panel loads are reduced, Wall Connector is able to increase charging current up to a limit set by the installer.

Supported System Configurations

Dynamic Power Management is compatible with single-phase, split-phase, and three-phase configurations where a single Wall Connector is installed. Other system configurations are not supported at this time.



REQUIRED EQUIPMENT

Tesla Remote Meter

The following kit is required:

- Tesla P/N APAC 2083765-00-x

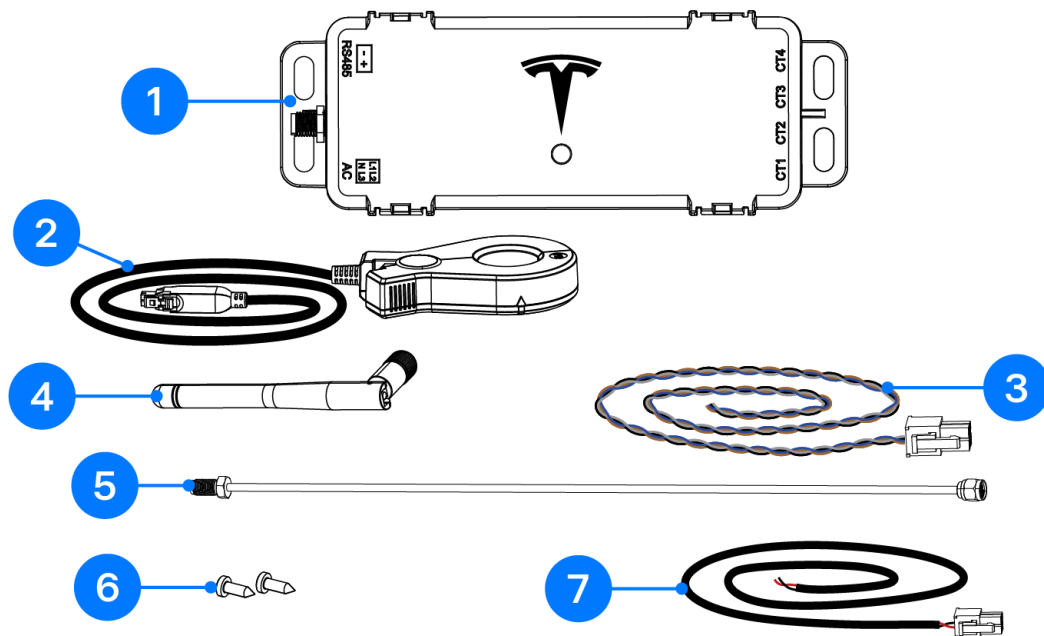

	Part Description	Quantity
1	Tesla Remote Meter	1
2	Tesla 200 A CT (1.5 m)	1
3	Voltage harness (600 mm)	1
4	External antenna	1
5	Antenna extension	1
6	Fasteners	2
7	RS485 Harness (P/N 2045794-xx-y)	1



NOTE: Neuroio CTs are *not* compatible with Tesla Remote Meter.



REQUIRED EQUIPMENT

Install type	Requirements
Single-phase with one line conductor	1 CT
Single-phase with two line conductors	2 CT
Three-phase	3 CT

 **NOTE:** If you require more CTs than provided in your region's kit for installation, individual CTs may be purchased (P/N 2033376-xx-y). 3.5m extensions for CTs may also be purchased (P/N 2060713-x-y)

Tesla Remote Meter Accessories

 **NOTE:** These accessories are not included in the Tesla Remote Meter kit. They must be ordered individually wherever required

Part Description	Tesla P/N	Quantity
Tesla 200 A CT (1.5 m)	2033376-xx-y	
CT extension (3.5 m)	2060713-xx-y	1

- Use 16 AWG shielded twisted pair cable to extend RS485 harness as needed.

 **NOTE:** The 600V-rated cable must be used if this wiring is to be run through the same conduit as the power circuits (if not, 300V-rated cable is sufficient).



INSTALL THE ENERGY METER



CAUTION: Never perform work on live circuits. De-energize the electrical panel before continuing.

1. Attach the energy meter's mounting plate to the inside of the electrical panel, and push the meter onto the plate.



NOTE: The energy meter requires of space inside the electrical panel. This clearance allows for the space required for routing wiring to the energy meter.



NOTE: The maximum distance the energy meter can be installed from the Wall Connector (wired RS-485 connection) is .

2. Wire the meter voltage taps:

- a. Connect the voltage line harness leads to a dedicated circuit breaker (not exceeding 20A) of corresponding phase inside the distribution board:

Voltage Harness Port/Wire Color	Distribution Board Connection
A/Red	L1 breaker terminal
B/White	L2 breaker terminal
C/Blue	L3 breaker terminal
N/Black	Neutral

- b. Plug the voltage line harness into the meter.



NOTE: If a dedicated breaker is not available, the voltage line harness can be spliced to existing breakers if allowed in your jurisdiction.

Figure 1. Configuration of remote meter inside panel - Single-phase

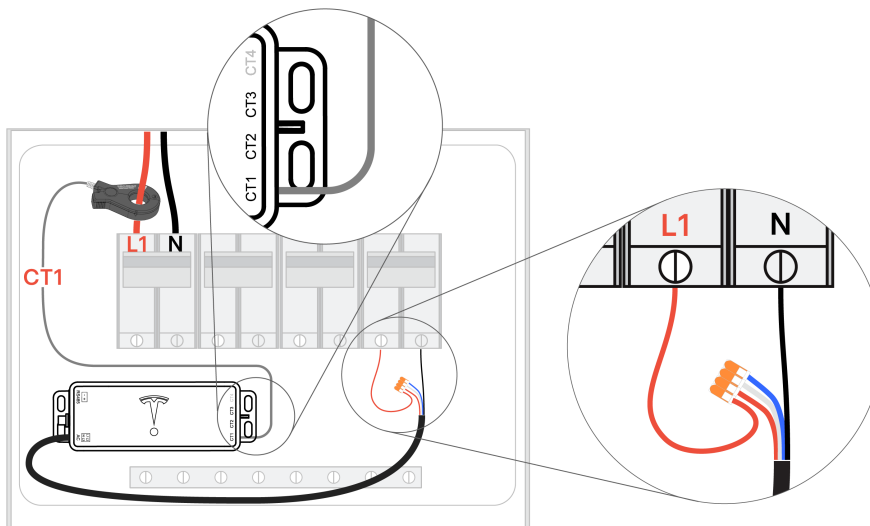



INSTALL THE ENERGY METER

Figure 2. Configuration of remote meter inside panel - Three-phase

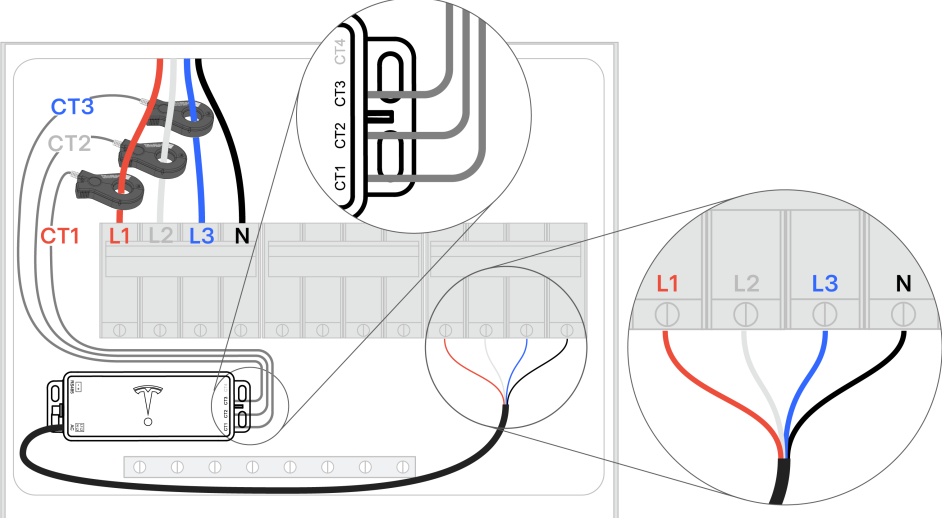



INSTALL THE ENERGY METER

Figure 3. Voltage Line Harness Wired to Dedicated Breaker (Top) or Spliced to Existing Breaker (Bottom) (Three Phase)

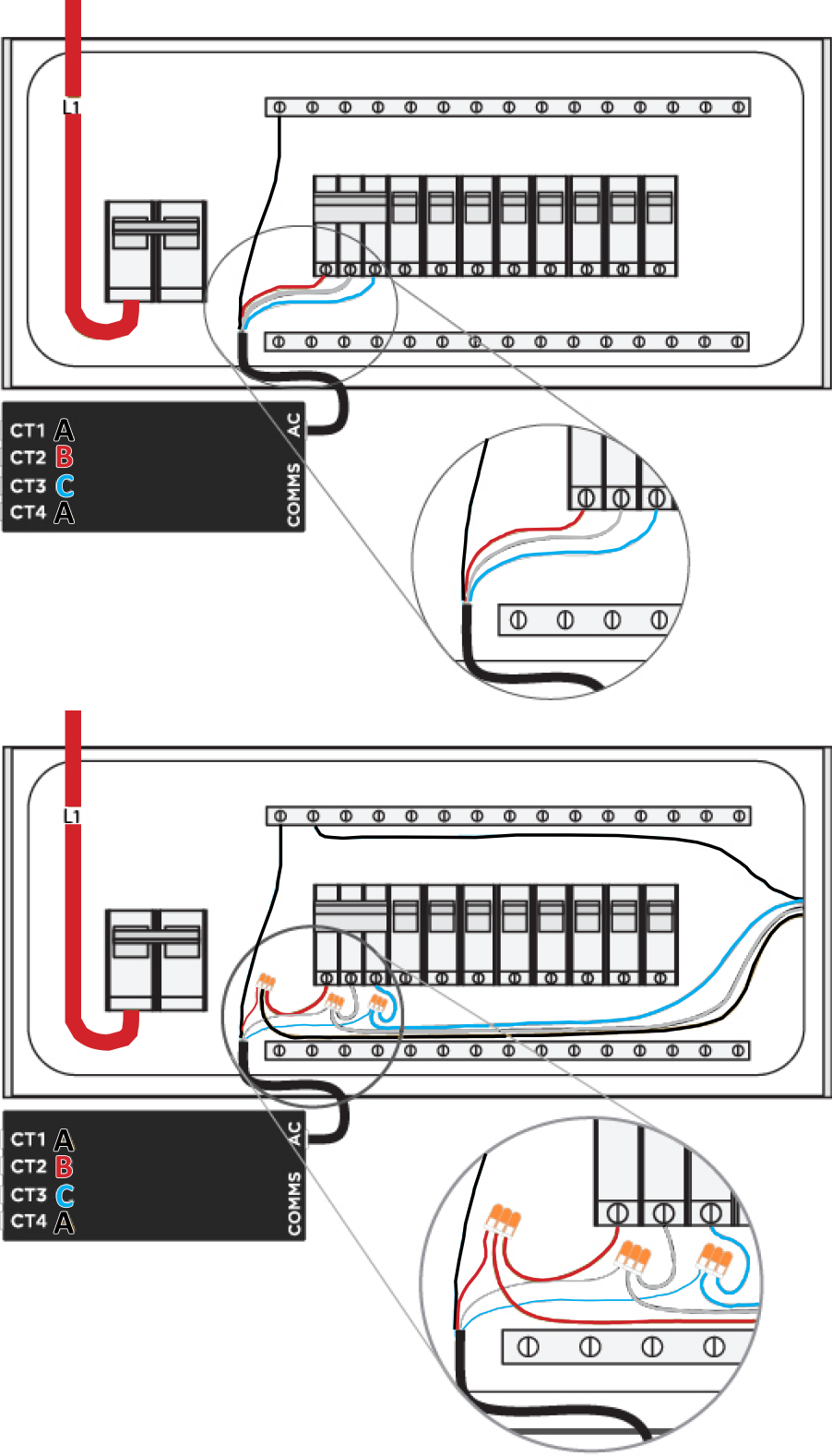

- 3. Install the current transformers (CTs):
 - a. Clip the CTs around - the main conductors feeding the panel.



INSTALL THE ENERGY METER

 **NOTE:** Ensure the "Source this Side" label faces away from the breakers, and towards the grid.

Figure 4. CT Orientation in Relation to Power Flow (Label to Face Power Source, in this Case Grid)

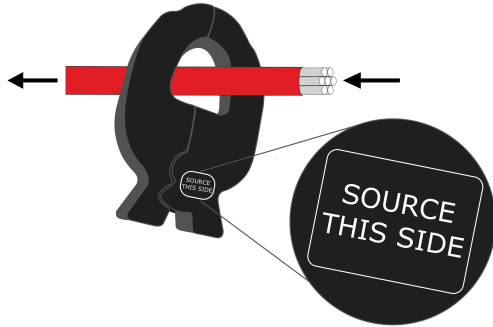

- b. Plug the CTs into the meter:
 - i. The CT measuring Line 1 can be plugged into either Port 1 or Port 4.



 **NOTE:** It is critical that each CT have the correct voltage reference. Ensure the CT is plugged into the correct port based on the phase it is measuring.

Figure 5. CT Measuring Single Phase System (CT on L1, Plugged into Port 1)

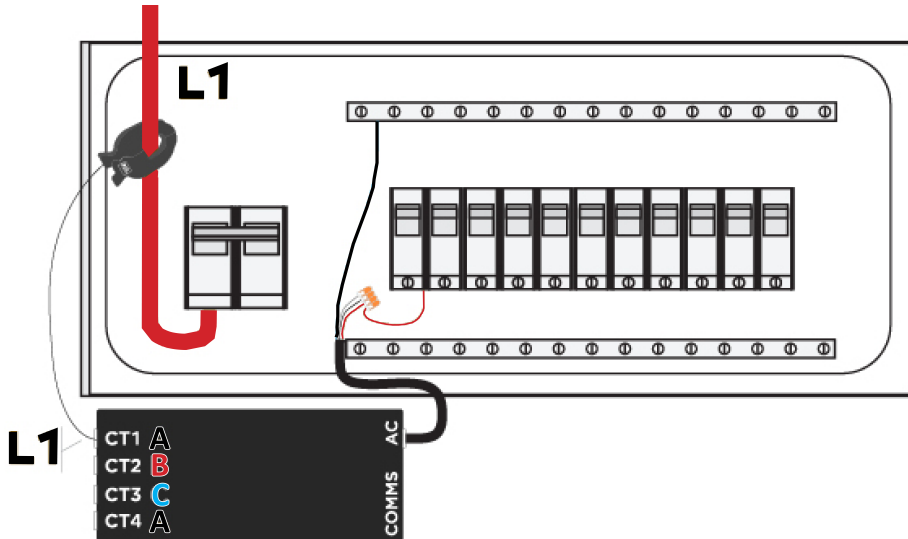

- 4. Establish a hardwired RS-485 connection between the Energy Meter and Wall Connector using the included 2-conductor wire harness:
 - a. Plug the provided wire harness into the port.
 - b. Extend the harness leads by splicing shielded twisted pair cable to the harness.
 - c. If applicable, land the drain wire on the ground bar in the panel.
 - d. Locate the terminals on the backside of Wall Connector.
 - e. Land the wire corresponding to the red lead of the harness to the red port, and the black lead to the white port.

 **NOTE:** The wiring configuration for RS485 is critical and cannot be reversed after installation, as improper setup may lead to operational failures or equipment damage. Ensure correct polarity and termination during initial installation.



INSTALL THE ENERGY METER

- f. Manage the communication wires so that they are not pinched when mounting the Wall Connector to the wire box.



5. Energize the panel and turn on the circuit breaker(s). The energy meter will chime when it has powered on and the meter LED will illuminate in green.



COMMISSION THE SYSTEM

1. Turn off any solar inverter(s) prior to commissioning. Turning off solar production ensures CT function can be confirmed as all CT measurements should be positive when there is no solar.
2. Confirm the breaker feeding the energy meter has been turned on.
3. Follow the standard procedure to commission Wall Connector in Tesla One (see [Wall Connector Device Setup in Tesla One](#) for complete instructions).
4. Ensure Wall Connector has been updated to firmware version **25.42.1** or greater. If Wall Connector is not connected to Wi-Fi, follow the [offline firmware updates procedure](#).
5. Once connected, the energy meter will automatically be detected. Select **Meter** to configure CTs and set the Max Conductor Limit.

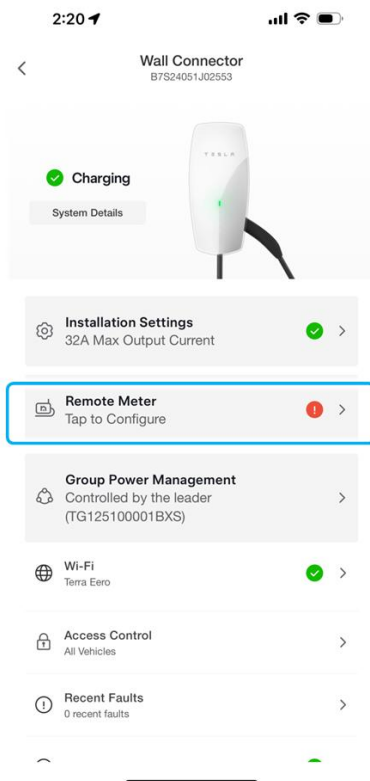



COMMISSION THE SYSTEM

6. Select the energy meter to configure the CTs.

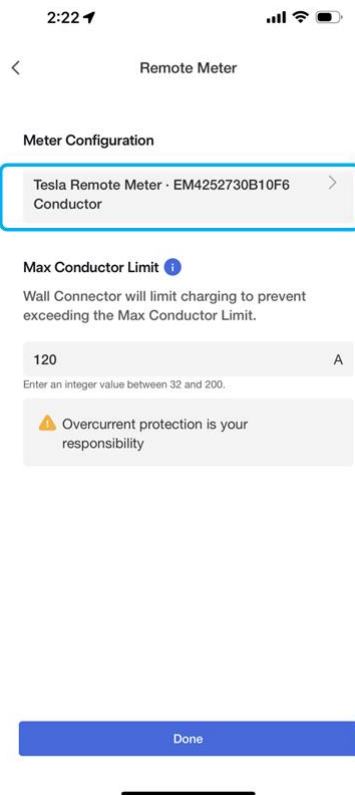

7. For each of the connected CTs, select the CT and set the **Location** to **Conductor**.

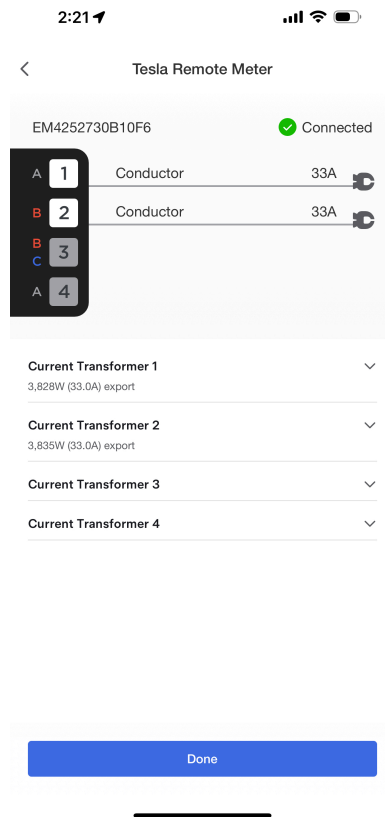
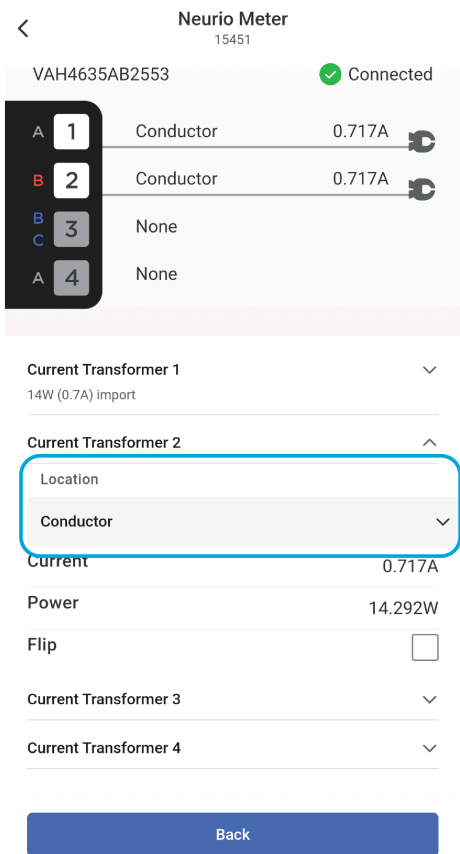



COMMISSION THE SYSTEM

8. On the **Meter** screen, set the **Max Conductor Limit**. This value should be 80% of the electrical panel's rated limit.
9. Test the system by turning on large loads in the panel and ensuring Wall Connector properly adjusts its charge rate. Alternatively, temporarily set the max conductor current lower than the actual limit of the electrical panel being measured. For example, if the conductor limit is 50A, temporarily set it to 32A. Confirm that this current limit is maintained by the Wall Connector by turning on some loads that would exceed the limit.



TROUBLESHOOTING

Energy Meter LED Indication

Tesla Remote Meter LED

The Tesla Remote Meter has an LED which indicates the following status:

Solid green ON	Powered and operational
----------------	-------------------------

Figure 6. Tesla Remote Meter LED Location

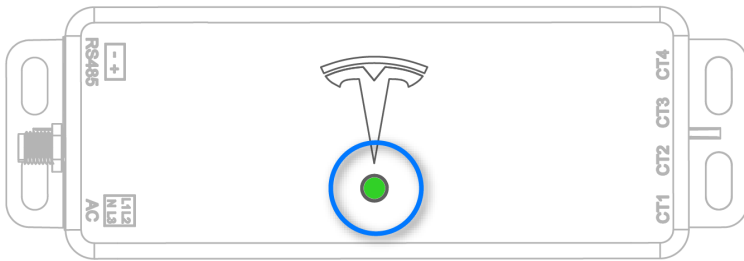



TRM not Appearing During Commissioning

If the Tesla Remote Meter is not appearing during commissioning:

- **Verify Power Supply:** Ensure the meter is properly energized and receiving power.
- **Check RS485 Configuration:** Confirm the RS485 wiring is correctly terminated, with proper polarity and no loose connections.
- **Validate Wi-Fi Connectivity:** Ensure the meter is within range of the WiFi network and that the network is stable and accessible.

Negative Site CT Value

The CT values in the Commissioning Wizard should be positive. If a CT value is negative:

1. Confirm **all** solar production has been turned off. Solar production greater than home consumption may result **in** negative readings
2. Confirm the CT is oriented correctly, with the "Source this Side" label facing toward the grid. If the CT is not oriented correctly, physically **flip it** or check the **Flip** box **in** the Commissioning Wizard.



REVISION HISTORY

Revision	Date	Description
1.0	2023-09-13	Initial publication
1.1	2023-11-21	<ul style="list-style-type: none">• Updated to reflect Dynamic Power Management as name of feature• Updated to reflect Tesla One commissioning experience
1.2	2024-01-22	<ul style="list-style-type: none">• Updated Overview on page 2 to include note and new section on supported system configurations• Updated Energy Meter LED Indication on page , removing old states and adding states when powered on and communicating with WC
1.3	6-6-24	Updated Tesla Pro to Tesla One
1.4	12-15-25	Updated to include information for Tesla Remote Meter
1.5	1-27-26	Updated Tesla Remote Meter to include harness.