

Wall Connector Application Note: Dynamic Power Management

Overview..... 2
Required Equipment..... 3
Install the Energy Meter..... 7
Commission the System.....11
Troubleshooting..... 14
 Energy Meter Chime Indication..... 14
 Energy Meter LED Indication.....15
 TRM not Appearing During Commissioning..... 16
 Negative Site CT Value..... 16
Revision History..... 17



OVERVIEW

As described in the [Wall Connector Installation Manual](#), the Gen 3 Wall Connector should be installed with a 60A circuit breaker for maximum power output (32A). In the event that there is not enough capacity for a 60A breaker in the electrical panel, a smaller breaker can be installed with a lower amperage configuration as follows:

Circuit Breaker (Amps)	Maximum Output (Amps)	Power Output 240V (kW)
60	48	11.5
50	40	9.6
40	32	7.6
30	24	5.7
20	15	3.8
15	12	2.8

The alternative to a smaller breaker is a costly panel upgrade.

Dynamic Power Management is a new feature that enables Wall Connector to dynamically adjust EV charging power based on live readings of the overall load in the panel. An energy meter is installed to monitor live current in the panel; when panel loads are reduced, Wall Connector is able to increase charging current up to a limit set by the installer.

Supported System Configurations

Dynamic Power Management is compatible with split-phase where a single Wall Connector is installed. Other system configurations are not supported at this time.



REQUIRED EQUIPMENT



REQUIRED EQUIPMENT

One of the following two kits is required:

Neurio Meter

- Energy meter kit: Tesla P/N 1938241-00-A



1	Energy meter
2	Current Transformers (CTs)
3	Voltage line harness
4	RS-485 communication harness



NOTE: The energy meter must be procured from Tesla as it ships with firmware required for this application.

- Wago 2-position and 3-position lever nuts for splicing communication harness and energy meter voltage harness where required
- Wire nut capping the blue voltage harness wire



REQUIRED EQUIPMENT

Tesla Remote Meter

- Tesla P/N North America 2045796-00-x

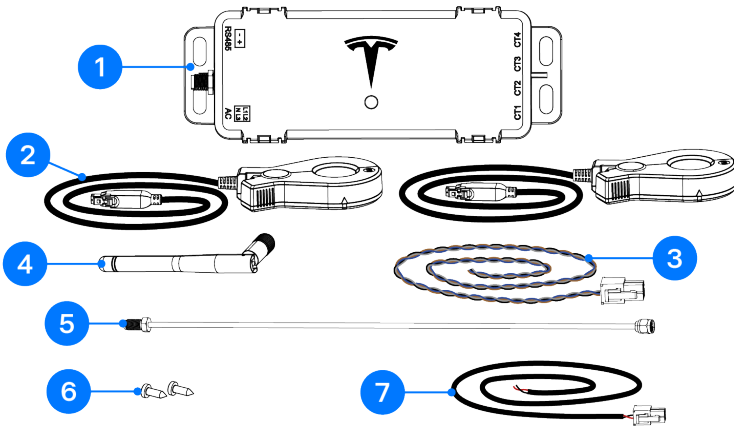

	Part Description	Quantity
1	Tesla Remote Meter	1
2	Tesla 200 A CT (1.5 m (59 in))	2
3	Voltage harness (600 mm (23.6 in))	1
4	External antenna	1
5	Antenna extension	1
6	Fasteners	2
7	RS485 Harness (P/N 2045794-xx-y)	1



NOTE: Neuroio CTs are *not* compatible with Tesla Remote Meter.

Install type	Requirements
Single-phase with one line conductor	1 CT
Single-phase with two line conductors	2 CT
Three-phase	3 CT



NOTE: If you require more CTs than provided in your region's kit for installation, individual CTs may be purchased (P/N 2033376-xx-y). 3.5m extensions for CTs may also be purchased (P/N 2060713-x-y)



REQUIRED EQUIPMENT

Tesla Remote Meter Accessories

 **NOTE:** These accessories are not included in the Tesla Remote Meter kit. They must be ordered individually wherever required.

Part Description	Tesla P/N	Quantity
Tesla 200 A CT (1.5 m (59 in))	2033376-xx-y	2
CT extension (3.5 m (138 in))	2060713-xx-y	1

 **NOTE:** The Wi-Fi antenna included in the energy meter kit are not used.

- Use 16 AWG shielded twisted pair cable to extend RS485 harness as needed.

 **NOTE:** The 600V-rated cable must be used if this wiring is to be run through the same conduit as the power circuits (if not, 300V-rated cable is sufficient).



INSTALL THE ENERGY METER



CAUTION: Never perform work on live circuits. De-energize the electrical panel before continuing.

1. Attach the energy meter's mounting plate to the inside of the electrical panel, and push the meter onto the plate.



NOTE: The energy meter requires 8 x 8 x 4 inches of space inside the electrical panel. This clearance allows for the space required for routing wiring to the energy meter.



NOTE: The maximum distance the energy meter can be installed from the Wall Connector (wired RS-485 connection) is 400 ft (122 m).

2. Wire the meter voltage taps:

- a. Connect the voltage line harness leads to a dedicated circuit breaker (not exceeding 20A) of corresponding phase inside the distribution board:

Voltage Harness Port/Wire Color	Distribution Board Connection
A/Black	L1 breaker terminal
B/Red	L2 breaker terminal
C/Blue	Capped with wire nut
N/White	Neutral busbar

- b. Plug the voltage line harness into the meter.



NOTE: If a dedicated breaker is not available, the voltage line harness can be spliced to existing breakers if allowed in your jurisdiction.



INSTALL THE ENERGY METER

Figure 1. Voltage Line Harness Wired to Dedicated Breaker (Left) or Spliced to Existing Breaker (Right)

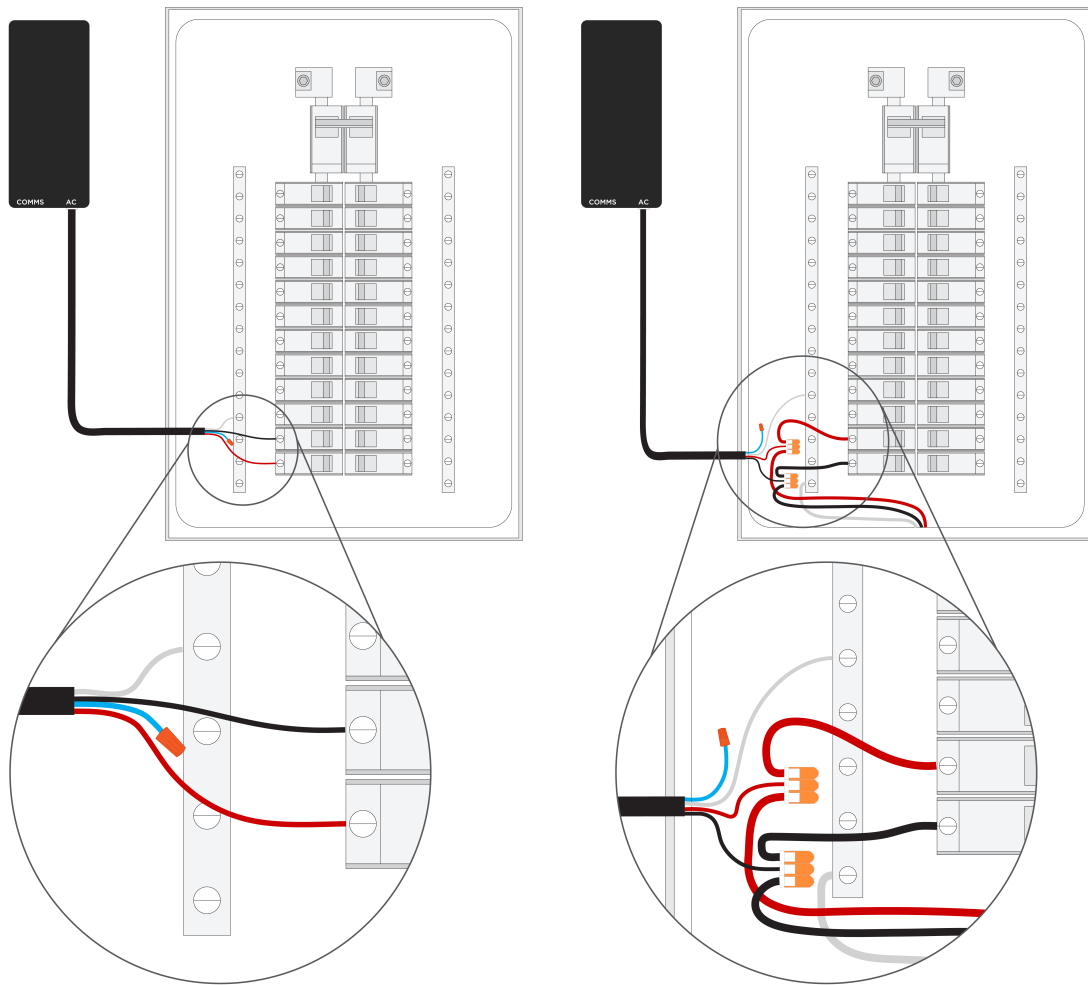

NOTE: The blue wire of the voltage line harness is capped with a wire nut for split phase installations. This wire is only needed for three-phase installations.

3. Install the current transformers (CTs):

- a. Clip the CTs around Line 1 and Line 2 of the Panel Service - the main conductors feeding the panel.



NOTE: Ensure the "Source this Side" label faces away from the breakers, and towards the grid.

Figure 2. CT Orientation in Relation to Power Flow (Label to Face Power Source, in this Case Grid)

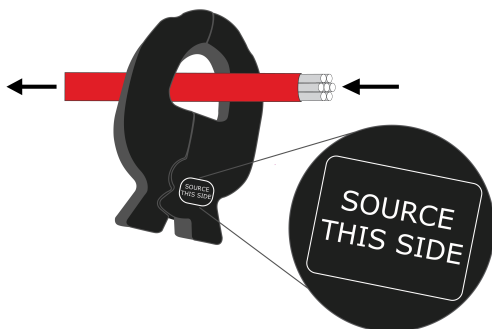

- b. Plug the CTs into the meter:



INSTALL THE ENERGY METER

- i. The CT measuring Line 1 can be plugged into either Port 1 or Port 4.
- ii. The CT measuring Line 2 must be plugged into Port 2.



NOTE: It is critical that each CT have the correct voltage reference. Ensure the CT is plugged into the correct port based on the phase it is measuring.

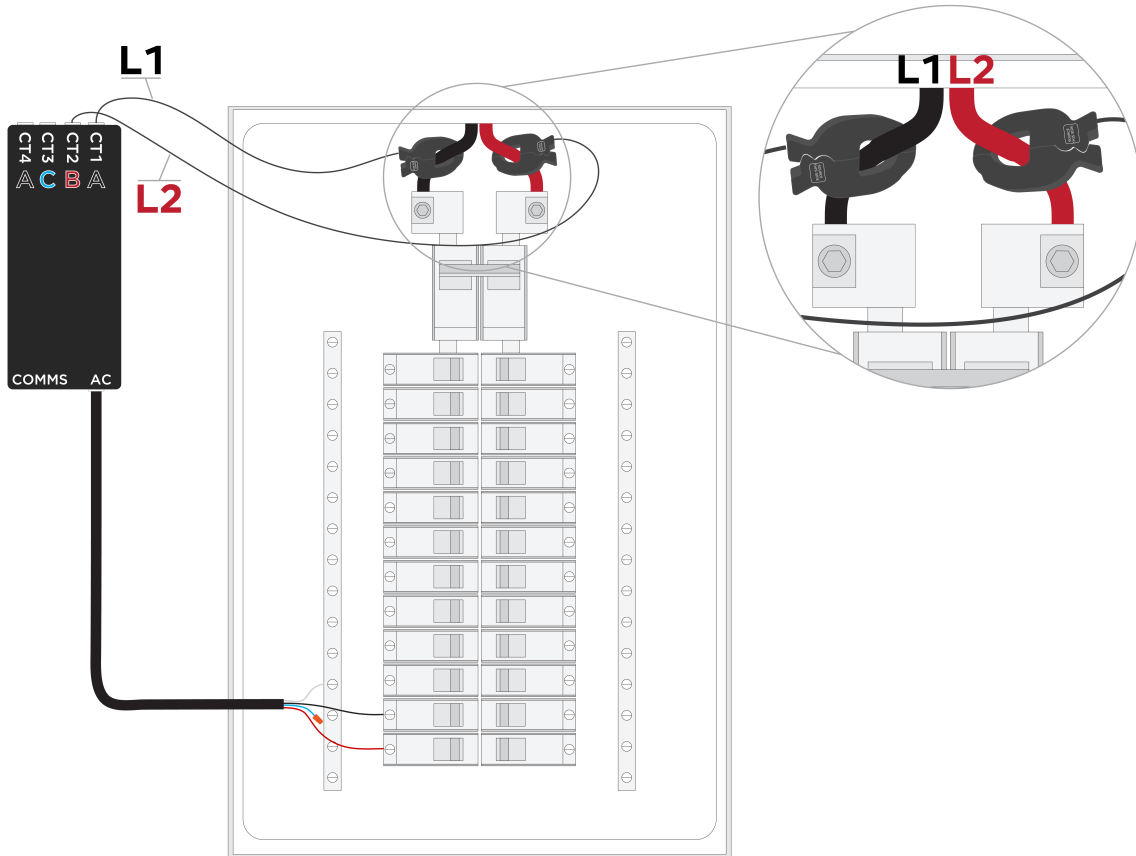

4. Establish a hardwired RS-485 connection between the Energy Meter and Wall Connector using the included 2-conductor wire harness:
 - a. Plug the provided wire harness into the port.
 - b. Extend the harness leads by splicing 16 AWG shielded twisted pair cable to the harness.
 - c. If applicable, land the drain wire on the ground bar in the panel.
 - d. Locate the terminals on the backside of Wall Connector.
 - e. Land the wire corresponding to the red lead of the harness to the red port, and the black lead to the white port.



NOTE: The wiring configuration for RS485 is critical and cannot be reversed after installation, as improper setup may lead to operational failures or equipment damage. Ensure correct polarity and termination during initial installation.



INSTALL THE ENERGY METER

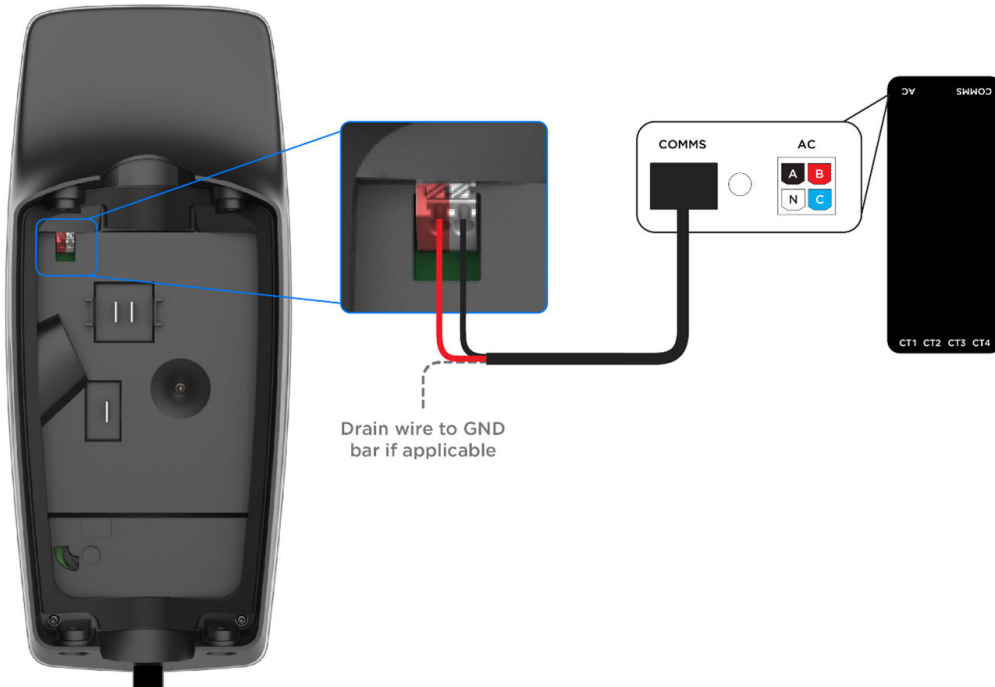

- f. Manage the communication wires so that they are not pinched when mounting the Wall Connector to the wire box.



5. Energize the panel and turn on the circuit breaker(s). The energy meter will chime when it has powered on and the meter LED will illuminate in green.



COMMISSION THE SYSTEM

1. Turn off any solar inverter(s) prior to commissioning. Turning off solar production ensures CT function can be confirmed as all CT measurements should be positive when there is no solar.
2. Confirm the breaker feeding the energy meter has been turned on.
3. Follow the standard procedure to commission Wall Connector in Tesla Pros (see [Wall Connector Device Setup in Tesla One](#) for complete instructions).
4. Ensure Wall Connector has been updated to firmware version **25.42.1** or greater. If Wall Connector is not connected to Wi-Fi, follow the [offline firmware updates procedure](#).
5. Once connected, the energy meter will automatically be detected. Select **Meter** to configure CTs and set the Max Conductor Limit.

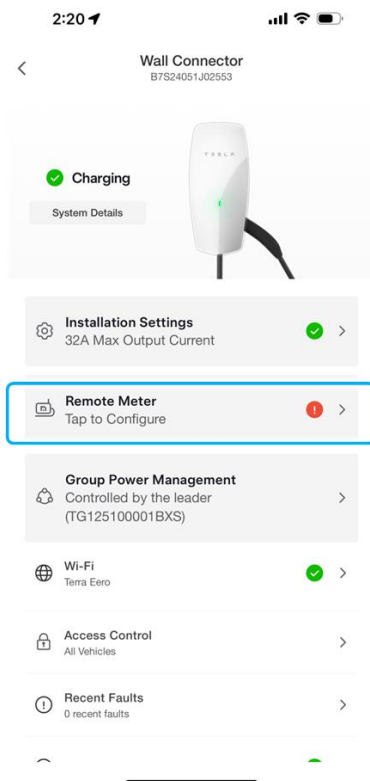



COMMISSION THE SYSTEM

6. Select the energy meter to configure the CTs.

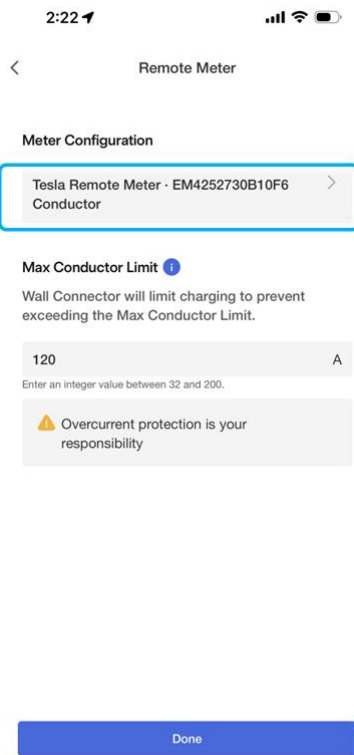

7. For each of the connected CTs, select the CT and set the **Location** to **Conductor**.

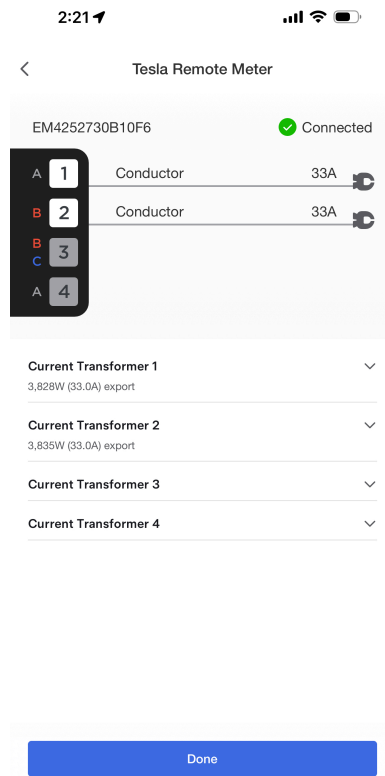
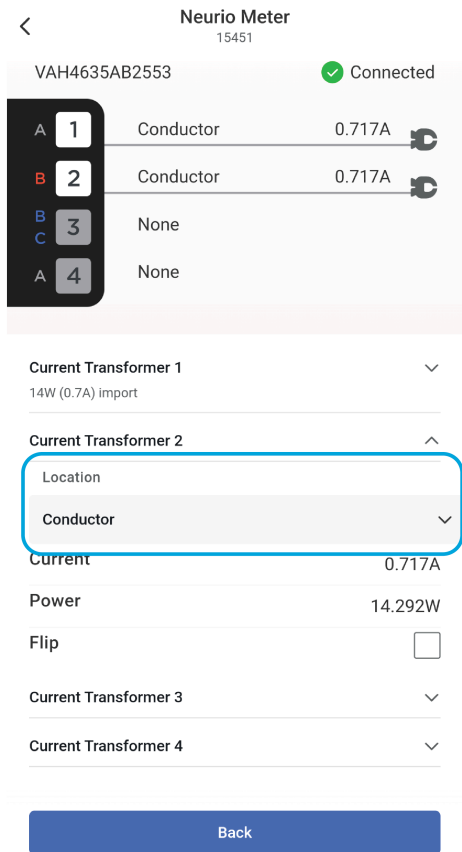



COMMISSION THE SYSTEM

8. On the **Meter** screen, set the **Max Conductor Limit**. This value should be 80% of the electrical panel's rated limit.

- See [Overview on page 2](#) for circuit breaker size options and the associated max conductor current ampacity for each circuit breaker size.
- For example, the max conductor current ampacity for a 60A breaker would be 48A.

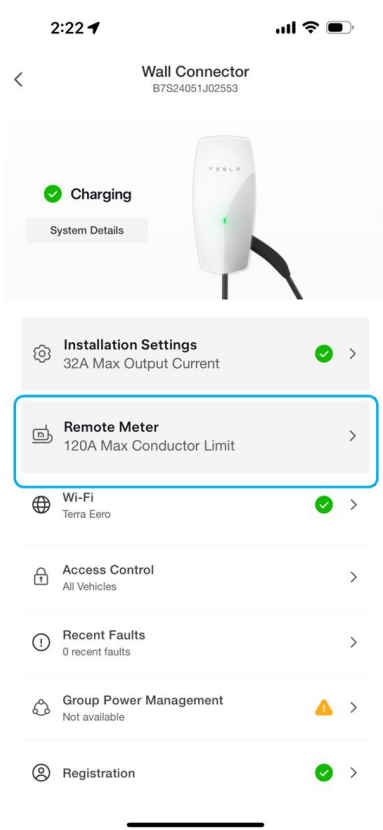





9. Test the system by turning on large loads in the panel and ensuring Wall Connector properly adjusts its charge rate. Alternatively, temporarily set the max conductor current lower than the actual limit of the electrical panel being measured. For example, if the conductor limit is 50A, temporarily set it to 32A. Confirm that this current limit is maintained by the Wall Connector by turning on some loads that would exceed the limit.



TROUBLESHOOTING

Energy Meter Chime Indication

Table 1. Neuroio Meter Chime Information

Tone	Indication	Description
Short Beeps 	Voltage check	One beep for each voltage wire that is connected.
Short Chime 	Energy meter Wi-Fi network started	Energy meter has started hosting its own Wi-Fi network. You can join this network to configure the energy meter and connect it to your own Wi-Fi network.
Long beep 	Voltage warning (conditional)	Indicates that two wires are connected to the same phase.
Long Chimes 	Energy meter joined network successfully	Energy meter successfully joined your Wi-Fi network.
Failing tone 	Energy meter failed to join network	Energy meter was unable to join your Wi-Fi network. Energy meter will now start hosting its own Wi-Fi network again to allow you to re-connect to the energy meter and re-enter the Wi-Fi credentials.



NOTE: TRM does not emit any chimes/audio cues.



Energy Meter LED Indication

Neurio Meter LED Indication

LED	Status	Behavior
Blue, then Green	Flashes blue, then turns solid green (whether or not comms wire is connected)	Energy Meter is Powered On
Green and Red	Flashes green and red	Energy meter is communicating with Wall Connector

Tesla Remote Meter LED

The Tesla Remote Meter has an LED which indicates the following status:

Solid green ON	Powered and operational
----------------	-------------------------

Figure 3. LED Location

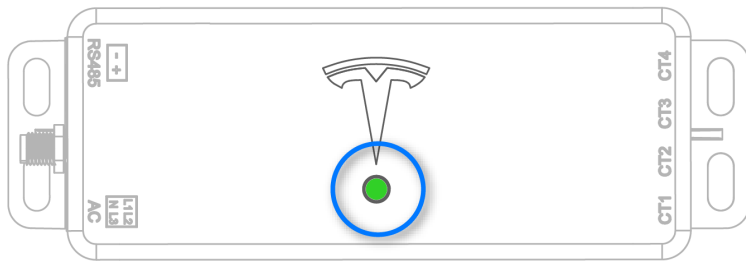



TRM not Appearing During Commissioning

If the Tesla Remote Meter is not appearing during commissioning:

- **Verify Power Supply:** Ensure the meter is properly energized and receiving power.
- **Check RS485 Configuration:** Confirm the RS485 wiring is correctly terminated, with proper polarity and no loose connections.
- **Validate Wi-Fi Connectivity:** Ensure the meter is within range of the WiFi network and that the network is stable and accessible.

Negative Site CT Value

The CT values in the Commissioning Wizard should be positive. If a CT value is negative:

1. Confirm **all** solar production has been turned off. Solar production greater than home consumption may result **in** negative readings
2. Confirm the CT is oriented correctly, with the "Source this Side" label facing toward the grid. If the CT is not oriented correctly, physically **flip it** or check the **Flip** box **in** the Commissioning Wizard.



REVISION HISTORY

Revision	Date	Description
1.0	2023-09-13	Initial publication
1.1	2023-11-21	<ul style="list-style-type: none">• Updated to reflect Dynamic Power Management as name of feature• Updated to reflect Tesla Pros commissioning experience
1.2	2024-01-22	<ul style="list-style-type: none">• Updated Overview on page 2 to include note and new section on supported system configurations• Updated Energy Meter LED Indication on page 15, removing old states and adding states when powered on and communicating with WC
1.3	6-6-24	Updated Tesla Pro to Tesla One
1.4	12-15-25	Updated to include information for Tesla Remote Meter
1.5	1-27-26	Updated Tesla Remote Meter to include harness.