



Universal Wall Connector Manual

48A Single Phase

Universal Wall Connector Installation Manual...
.....

Important Safety Information..... 2

General Warnings and Information..... 5

Product Overview..... 6

Product Specifications..... 6

Circuit Breaker Rating / Maximum Output..... 8

Using Wall Connector..... 10

Features..... 11

Connectivity..... 11

Hosted Access Point..... 11

Local Network..... 12

Ground Fault Circuit Interruption..... 13

Ground Assurance..... 13

Power Outages..... 13

Firmware Updates..... 14

Wall Connector External Components..... 15

Wall Connector Internal Components..... 16

Installation..... 17

In the Box..... 17

Tools..... 18

Installation Considerations..... 18

Step 1: Prepare Wirebox for Conduit Fittings..... 22

Step 2: Prepare Mounting Surface..... 24

Step 3: Prepare Wirebox and Mount to Wall..... 25

Step 4: Route Wiring Through Wirebox..... 26

Step 5: Strip and Land Wiring..... 27

Step 6: Attach Wall Connector to Wirebox..... 28

Step 7: Energize Wall Connector..... 29

Commissioning Procedure..... 30

Perform Device Setup..... 32

Software Updates..... 33

Complete Registration..... 33

Address Alerts..... 40

System Details..... 42

Optional: Access Controls..... 42

Optional: Dynamic Power Management..... 43

Optional: Group Power Management..... 45

Operating and Error States..... 47

Device Registration..... 48

Static Power Management..... 52

Dynamic Power Management..... 54

Group Power Management..... 57

Group Power Management Overview..... 57

Breaker and Branch Circuit Setup..... 58

Considerations for Group Power Management..... 60

Calculating Group Power Management Requirements
for Existing Systems..... 60

Setting Up Group power management..... 60

How to View Existing Group Power Management
Networks..... 66

Enabling Commercial Charging Features..... 67

Wall Connector LEDs..... 68

Light Codes..... 68

Fault Codes..... 69

Electric Vehicle Service Equipment (EVSE)
Communication Codes..... 70

Torque Specifications..... 71

Warranty Information..... 72

Limits of Liability..... 73

Dispute Resolution..... 74

Appendix A: Daisy Chaining Multiple Wall
Connectors..... 76

Daisy Chaining Multiple Wall Connectors..... 76

.....



IMPORTANT SAFETY INFORMATION

Read all instructions before using this product. Save these instructions.

This manual contains important instructions for the Universal Wall Connector that shall be followed during installation, operation, and maintenance. Please review all warnings and cautions before installing and using the Wall Connector.

 **WARNING:** When using electric products, basic precautions should always be followed, including the following.

INSTRUCTIONS RELATING TO RISK OF FIRE OR ELECTRIC SHOCK

 **WARNING:** Do not install or use the Wall Connector near flammable, explosive, harsh, or combustible materials, chemicals, or vapors.

 **WARNING:** Turn off power at the circuit breaker before installing or cleaning the Wall Connector.

WARNINGS

 **NOTE:** When using Eaton branch breakers for Powerwall, Tesla recommends using the following when the electrical panelboard is made of aluminum:

- Eaton **BRH** branch breakers
- Eaton BR branch breakers with part numbers ending in **H** (e.g. BR260H)

 **WARNING:** This product can expose you to one or more chemicals that are known to the state of California to cause cancer.

 **WARNING:** This device should be supervised when used around children.

 **WARNING:** The Wall Connector must be grounded through a permanent wiring system or an equipment-grounded conductor.

 **WARNING:** Use the Wall Connector only within the specified operating parameters.

 **WARNING:** Never spray water or any other liquid directly at the wall mounted control box. Never spray any liquid onto the charge handle or submerge the charge handle in liquid. Store the charge handle in the dock to prevent unnecessary exposure to contamination or moisture.

 **WARNING:** Do not use the Wall Connector if it is defective, appears cracked, frayed, broken, or otherwise damaged, or fails to operate.

 **WARNING:** Do not use the Wall Connector if the flexible power cord or cable is frayed, broken, or otherwise damaged, or fails to operate.

 **WARNING:** Do not attempt to disassemble, repair, tamper with, or modify the Wall Connector. The Wall Connector is not user serviceable. Contact Tesla for any repairs or modification.



IMPORTANT SAFETY INFORMATION

WARNING: When transporting the Wall Connector, handle with care. Do not subject it to strong force or impact or pull, twist, tangle, drag, or step on the Wall Connector, to prevent damage to it or any components.

WARNING: Do not touch the Wall Connector's end terminals with fingers or sharp metallic objects, such as wire, tools, or needles.

WARNING: Do not insert fingers or foreign objects into any part of the Wall Connector.

WARNING: Do not forcefully fold or apply pressure to any part of the Wall Connector or damage it with sharp objects.

WARNING: Use of the Wall Connector may affect or impair the operation of any medical or implantable electronic devices, such as an implantable cardiac pacemaker or an implantable cardioverter defibrillator. Check with your electronic device manufacturer concerning the effects that charging may have on such electronic devices before using the Wall Connector.

FCC

This device complies with part 15 of the FCC Rules. Operation is subject to the following two conditions: (1) This device may not cause harmful Interference, and (2) this device must accept any interference received, including interference that may cause undesired operation.

15.21 - Changes or modifications not expressly approved by the party responsible for compliance could void the user's authority to operate the equipment

15.105 (b) - This equipment has been tested and found to comply with the limits for a Class B digital device. pursuant to part 15 of the FCC Rules. These limits are designed to provide reasonable protection against harmful interference in a residential installation. This equipment generates, uses and can radiate radio frequency energy and, if not installed and used in accordance with the instructions may cause harmful interference to radio communications. However, there is no guarantee that interference will not occur in a particular installation. If this equipment does cause harmful interference to radio or television reception, which can be determined by turning the equipment off and on, the user is encouraged to try to correct the interference by one or more of the following measures:

- Reorient or relocate the receiving antenna.
- Increase the separation between the equipment and receiver.
- Connect the equipment into an outlet on a circuit different room that to which the receiver is connected.
- Consult the dealer or an experienced radio/TV technician for help.

RF Exposure Information (MPE)

This device has been tested and meets applicable limits for Radio Frequency (RF) exposure. This equipment should be installed and operated with minimum distance 20 cm between the radiator and your body.

ISED Canada Compliance Statement

This device contains license-exempt transmitter(s)/receiver(s) that comply with Innovation, Science and Economic Development Canada's license-exempt RSS(s). Operation is subject to the following two conditions: (1) this device may not cause interference, and (2) this device must accept any interference, including interference that may cause undesired operation of the device.



IMPORTANT SAFETY INFORMATION

CAUTIONS



CAUTION: Do not use private power generators as a power source for charging.



CAUTION: Incorrect installation and testing of the Wall Connector could potentially damage the vehicle's battery, components, and/or the Wall Connector itself. Any resulting damage is excluded from the New Vehicle Limited Warranty and the Charging Equipment Limited Warranty.



CAUTION: Do not operate the Wall Connector in temperatures outside its operating range of -22°F to 122°F (-30°C to 50°C).



CAUTION: Wall Connector should only be installed by personnel who are trained and qualified to work on electrical systems.



CAUTION: Ensure that Wall Connector is within storage temperature when moving, transporting, or storing.

Notes



NOTE: Ensure that the Wall Connector's charging cable is positioned so it will not be stepped on, driven over, tripped on, or subjected to damage or stress.



NOTE: Do not use cleaning solvents to clean any of the Wall Connector's components. The outside of the Wall Connector, the charging cable, and the connector end of the charging cable should be periodically wiped with a clean, dry cloth to remove accumulation of dirt and dust.



NOTE: : Be careful not to damage the circuit boards or components during installation.











NOTE: Use a cable sheath or similar containment to cover the supply cables. The color black is recommended.



GENERAL WARNINGS AND INFORMATION

Symbols Used

	CAUTION: Indicates a hazardous situation which, if not avoided, could result in minor injury or damage to the equipment.		RISK OF ELECTRIC SHOCK: Indicates components that present risk of electrical shock.
	WARNING: Indicates a hazardous situation which, if not avoided, could result in injury or death.		CAUTION, RISK OF ELECTRIC SHOCK, ENERGY STORAGE TIMED DISCHARGE. Discharge time is 5 minutes from de-energization.
 NOTE:	NOTE: Indicates an important step or tip that leads to best results, but is not safety or damage related.		BIDIRECTIONAL TERMINAL: Indicates location of combined input/output connector on the equipment.
	REFER TO OPERATING INSTRUCTIONS: Indicates that user should refer to operating or installation instructions before proceeding.		PROTECTIVE CONDUCTOR TERMINAL: Indicates location of grounding connection on the equipment.



PRODUCT OVERVIEW

Product Specifications

This manual applies to Wall Connectors identified by part number 1734412-XX-X.

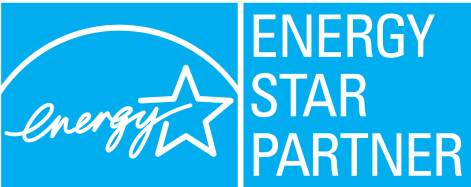
Voltage and Wiring	Nominal 200-240 V AC single-phase
Current Output Range	12 – 48 amps
Terminal Blocks	12-4 AWG G (3.5 - 25 mm ²), copper
Supported Conduit Sizing	¾" (21 mm) default, 1" (27 mm) optional
Grounding Scheme	TN/TT
Frequency	50/60 Hz
Cable Length	24 ft (7.3 m)
Wall Connector Dimensions	Height: 13.6 in (345 mm) Width: 6.1 in (155 mm) Depth: 5.9 in (150 mm)
Wire Box Bracket Dimensions	Height: 9.8 in (250 mm) Width: 4.7 in (120 mm) Depth: 3.5 in (90 mm)
Weight (including wirebox)	~13lbs (5.7kg)
Operating Temperature	-22 ° F to 122 ° F (-30 ° C to 50 ° C)
Storage Temperature	-40 ° F to 185 ° F (-40 ° C to 85 ° C)
Enclosure Rating	Type 3R IP 54
Ventilation	Not required
Means of Disconnect	External branch circuit breaker
Wi-Fi	2.4 GHz, 802.11b/g/n
Agency Approvals	ETL/cETL
	



PRODUCT OVERVIEW

Transportation and storage: Ensure that Wall Connector is within storage temperature when moving, transporting, or storing.

This device complies with part 15 of the FCC Rules. Operation is subject to the following conditions: (1) This device may not cause harmful interference, and (2) this device must accept any interference received, including interference that may cause undesired operation.

This device is equipped with a power line communication (PLC) chip that has capability to be software updated in the future for supporting plug and charge applications via ISO15118 protocol with compatible vehicles.



Circuit Breaker Rating / Maximum Output

Power Output

For maximum power output, install a standard double pole 60 amp circuit breaker.

Wall Connector incorporates automatic load management, which allows the max output to be customized to an existing power supply.

If the electrical supply is unable to support the 60 amp configuration, select a lower amperage configuration.

Circuit breaker (amps)	Max output (amps)	Power output at 240 volts (kW)
60	48	11.5
50	40	9.6
40	32	7.6
30	24	5.7
20	16	3.8
15	12	2.8



NOTE: External disconnect switches are neither required nor recommended.



NOTE: Circuit breaker size is programmed during the commissioning process. See [Commissioning Procedure on page 30](#) for details.



NOTE: Some Tesla vehicles may draw less current than the max output. Actual charging rate depends on Wall Connector output and onboard charger in the vehicle.

Branch Circuit Conductors and Ground Wire



NOTE:

- Eaton **BRH** branch breakers
- Eaton BR branch breakers with part numbers ending in **H** (e.g. BR260H)

- If installing for less than maximum power, refer to local electrical code to select correct conductors and ground wire size that are suitable for the chosen circuit breaker.
- For maximum power, check temperature rating of circuit breaker used:
 - For 60°C rated circuit breaker, use minimum 4AWG, 90°C THWN-2-rated copper wire for conductors.
 - For 75°C rated circuit breaker, use minimum 6AWG, 90°C THWN-2-rated copper wire for conductors.



NOTE: Increase conductor size if necessary.

- For sites with multiple Wall Connectors, the group power management feature can enable the safe utilization of a single branch circuit. See single line examples in [Breaker and Branch Circuit Setup on page 58](#).
- COPPER WIRE TERMINATIONS ONLY for landing in Wall Connector wirebox terminals. Conductors can be stranded or solid.
- Hardwire branch circuits to disconnects or circuit breakers. Do **NOT** install cord-and-plug type connections.



PRODUCT OVERVIEW

- For outdoor installations, use watertight fittings when securing feeder wires to the wirebox.

Grounding Connections

Wall Connector must have a ground path back to the main equipment earthing point on site. Without a proper ground connection, the Wall Connector will fault during a ground assurance test. Equipment-grounding conductor must be run with the circuit conductors and connected to the equipment-grounding terminal in the wirebox. Install a ground (PE) wire sized according to local electrical code.



Using Wall Connector

1. To use NACS handle, remove the NACS connector from the holster.



To use J1772 handle, press the black button on the J1772 adapter to remove the handle from the dock.



2. Insert the charge handle into the vehicle charge port.
3. Check the vehicle controls or the Tesla app to verify charging.
4. To remove the charge handle from the vehicle, press and hold the button on the handle to unlock the charge port.



NOTE: The vehicle must be unlocked for the charge handle to be removable.

5. Remove the charge handle from the vehicle charge port.
6. Wrap the charge cable counter-clockwise around the Wall Connector and insert the charge handle into the holster.





Features

Connectivity

Wall Connector is equipped with Wi-Fi to communicate with local site routers, vehicles, mobile devices, other Wall Connectors, and other Tesla products.

Press and hold the button on the connector for 5 seconds. The Wall Connector will then be available to connect to WiFi for 15 minutes.

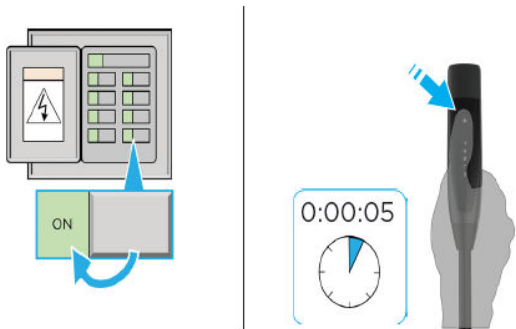

Hosted Access Point

Wall Connector hosts a WPA2 password-secured, 2.4 GHz, 802.11 Wi-Fi access point network to facilitate commissioning and connecting to other devices.

A unique SSID Wi-Fi network name and WPA2 password for connecting to the Wall Connector are printed on a label at the rear of the main unit, as well as on the front cover of the Quickstart Guide included in the box.



PRODUCT OVERVIEW

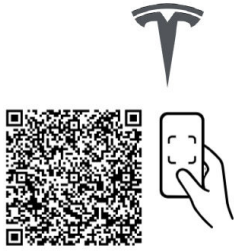

TPN: 1457768-01-G
TSN: B7520280V02809
SSID: TeslaWallConnector_1E1E09
WPA2: TESDVDXMJXRX



Universal Wall Connector



Quickstart Guide
Guía Rápida
Guide Rapide
クイックガイド
빠른 설치 설명서
快速入门指南

Local Network

Connecting Wall Connector to a local Wi-Fi network enables it to receive over-the-air firmware updates, remote diagnostics access, and usage data tracking capability. A Wi-Fi connection is required for sites that utilize authentication, billing, and other property management features.

Wall Connector only supports WPA2/3-secured, 2.4 GHz, 802.11 infrastructure mode networks.

 **NOTE: Networks that are not password protected are not supported. The Wall Connector will not display non-password protected networks in the options list.**



Ground Fault Circuit Interruption

Integrated ground fault circuit interruption (GFCI) protection automatically detects a current mismatch between power delivery conductors that would indicate that current is flowing through the ground (PE) conductor.

If a ground fault occurs after 10 seconds of charging, Wall Connector will wait 15 minutes before automatically re-attempting to charge. Up to four attempts to charge will be made before user interaction is required.

If a ground fault occurs within 10 seconds of charging, Wall Connector will lock out and user interaction is required to restore charging functionality.

Recommended interaction includes pressing the button on the charging handle, or removing the charging handle from the vehicle and reinserting it. If this does not resolve the issue, look for a ground fault issue such as water ingress.

Ground Assurance

Wall Connector continuously checks for the presence of a safe ground connection and automatically recovers from faults. Ground assurance operates by injecting a small amount of current into the ground conductor in order to measure the impedance between line and ground. If high impedance is detected, the Wall Connector will lock out charging and display a fault code of two (2) red blinks. See [Fault Codes on page 69](#) for a full list of fault codes.

For ground assurance to operate on TN grids, one leg of the distribution transformer must be ground -bonded (Neutral). Ground bond should only occur at one location in a site's electrical system.

Wall Connector ground assurance may be adjusted in countries with TT or IT grid configurations and can be disabled in the commissioning procedure.

The Ground Monitor Interrupter feature monitors the Wall Connector ground connection. Select the correct option based on the installation's earthing system and earth impedance.

Depending on country, three options are available:

- **Enable:** Ground connection will be monitored and a high detected. Ground resistance will disable the Wall Connector. This is the preferred setting to provide protection, and should be selected where ground connection is expected to be strong (as in the case on TN networks and most TT networks), and where required by regulation.
- **Monitor:** Ground connection will be monitored but a high detected ground resistance will not disable the Wall Connector. This should be selected if the ground monitoring check yields false positives and ground impedance cannot be improved (as is the case in some TT networks).
- **Disabled:** Ground connection will not be monitored. This should be selected where the ground connection is not made (as is the case for IT networks), or where the current induced by this check would be problematic (as is the case on some TT networks with sensitive residual-current devices).



NOTE: Ground Monitoring is always enabled for installations in North America.

Temporary problems such as ground faults or utility power surges are resolved automatically.

Power Outages

If there is a power outage while Wall Connector is charging a vehicle, charging will automatically resume within 1 to 3 minutes after power restoration. The Wall Connector will display a solid blue light on the faceplate to indicate that it is communicating with the vehicle and waiting to resume charging. Alternatively, pressing the button on the charge handle after power restoration will cause Wall Connector to resume charging immediately.



NOTE: Wall Connectors in a group power management maintain their settings after a power loss event.

Firmware Updates

Firmware updates will be automatically applied to the Wall Connector to improve the user experience and introduce new features. Connect Wall Connector to Wi-Fi for access to the most recent firmware update. See [Commissioning Procedure on page 30](#).



Wall Connector External Components

"Wall Connector" refers to the product as a whole.

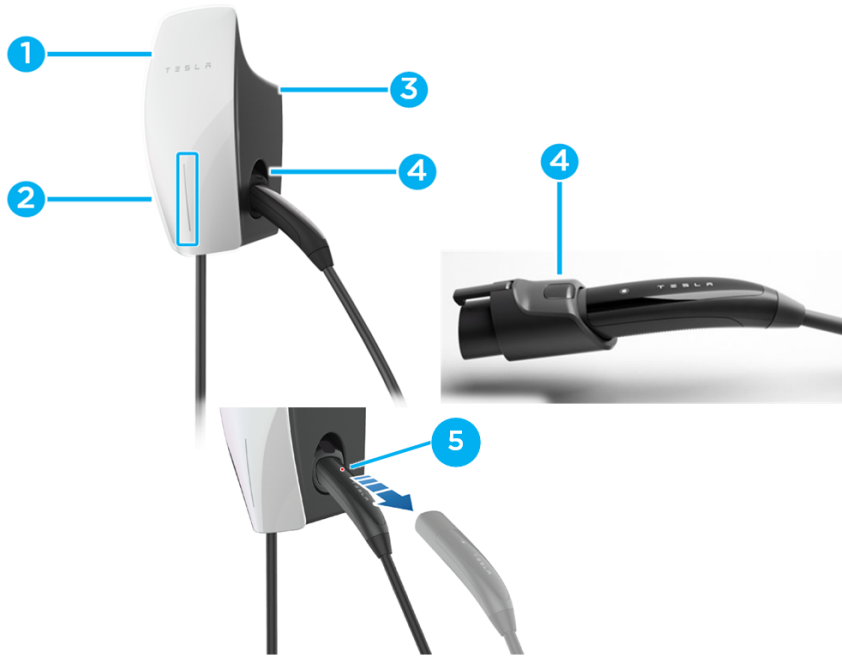

1. Faceplate
2. Light bar (vertical)
3. Main unit
4. J1772 charge port adapter
5. NACS handle



Wall Connector Internal Components

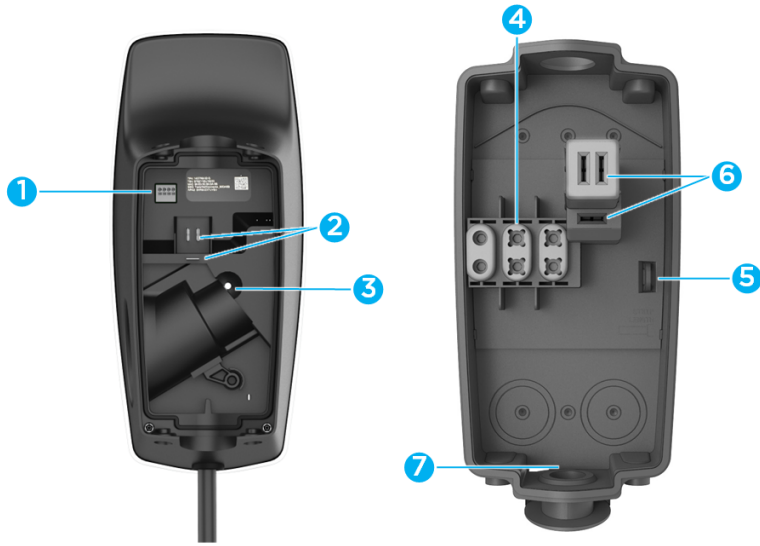









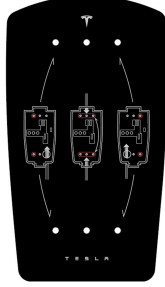

1. RS-485 port
2. Contact blades
3. Temperature sensor
4. Conductor terminals
5. Zip tie anchor
6. Sliding contacts
7. Wirebox drainage opening (enables Type 3R protection)



INSTALLATION

In the Box

 <p>Main Unit</p>	 <p>Wirebox</p>	 <p>Wirebox Mounting Template</p>	 <p>Hex Bit 4 mm</p>	
 <p>Zip tie (x1)</p>	 <p>Main Unit-to-Wirebox Fastener (x4)</p>	 <p>Wirebox-to-Wall Fastener (x2)</p>	 <p>Quickstart Guide (contains sticker with SSID network name and unique password)</p>	 <p>Sticker for breaker</p>

 **NOTE:** The hex bit, zip tie, and fasteners are located in a plastic bag inside the wirebox, which comes attached to the main unit of the Wall Connector.

 **NOTE:** Wall anchors are not included. If installing in concrete or other like materials, use ¼ in (6 mm) wall plugs.









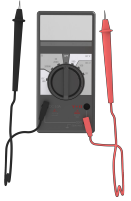

INSTALLATION

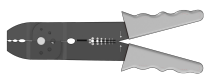

Tools

Required Tools

 **NOTE:** Drill bit sizes assume wood mounting surfaces.

 <p>Torque Driver (50 in lb) (5.6 Nm)</p>	 <p>Insulation Multimeter Fluke 1587 FC or equivalent (rated for equipment voltage)</p>	 <p>Stud Finder</p>	 <p>Tape Measure</p>
 <p>Wire Stripper</p>	 <ul style="list-style-type: none"> • Drill Bit, 3/32 in (2.5 mm) • Drill Bit, 3/16 in (5 mm) 	 <p>Phillips bit</p>	 <p>Bit Driver</p>
 <p>Level</p>	 <p>Smartphone (with Wi-Fi)</p>	 <p>Power Drill</p>	

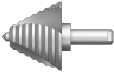
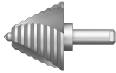
Optional Tools

 <p>Step Bit, 1-1/8 in (29 mm)</p>	 <p>Step Bit, 1-3/8 in (35 mm)</p>	 <p>Computer (with Wi-Fi)</p>
---	---	--

Installation Considerations

Wall Connector may be installed on any flat, vertical surface capable of supporting its weight (e.g. wall, pedestal, etc.). Wall Connector weighs ~13lbs (5.7kg).



INSTALLATION

Choosing Location

Install Wall Connector in a location that allows the charge cable to reach the vehicle charge port without putting strain on the cable. Recommended installation area for Wall Connectors with 24 ft (7.3 m) cable:

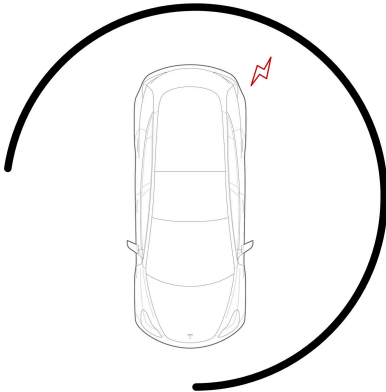

Install Wall Connector in a location with ample clearance on all sides to allow the charge cable to loop around the unit and the charge handle to comfortably land in the side dock.





INSTALLATION

Choosing Height



- Maximum height (indoor and outdoor): 60 in (1.52 m)
- Recommended height: ~45 in (~1.15 m)
- Minimum outdoor height: 24 in (0.6 m)
- Minimum indoor height: 18 in (0.45 m)



Maximizing Wi-Fi Signal Reception

Wall Connectors should be connected to a local Wi-Fi network for optimal functionality. For maximum signal reception, avoid installing Wall Connector on opposite sides of concrete, masonry, metal studs, and other physical obstructions that could impede Wi-Fi signal reception.

 **NOTE:** If a mobile device is able to connect to local Wi-Fi at a given location, it is a good indication that Wall Connector will also be able to connect.



Wire Entry Options

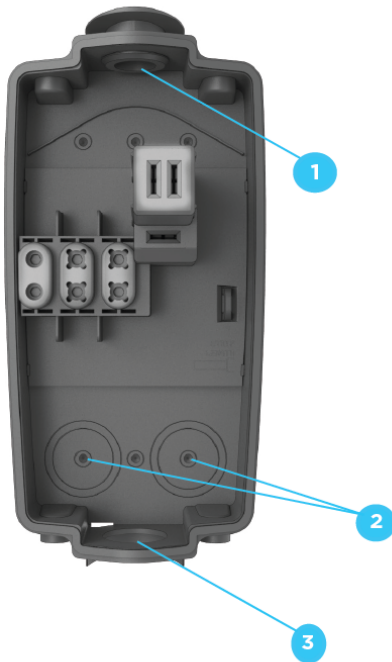

Wall Connector's wirebox has multiple wire entry options. Choose one entry path and follow installation instructions based on chosen entry path.

1. Top entry location
2. Rear entry locations (left or right)
3. Bottom entry location

For additional installation considerations on sites that will have multiple Wall Connectors, see [Considerations for group power management on page 60](#).



Step 1: Prepare Wirebox for Conduit Fittings

The default conduit size is conduit is acceptable if needed. Ensure that the conduit hub used are rated Type 3R.

Based on fittings and conduit size, prepare the wirebox.

- For top or bottom entry: Manually remove the conduit plug.
- For rear entry: Drill with step bit to prepare wirebox for fittings.

Table 1. For Conduit

Top Entry	Bottom Entry	Rear Left Entry	Rear Right Entry

Table 2. For 1 in (27 mm) Conduit

Top Entry	Bottom Entry	Rear Left Entry	Rear Right Entry
Do not expand.			



INSTALLATION



NOTE: For 1 in (27 mm) rear and bottom entry options, drill with 1-3/8 in (35 mm) step bit to prepare wirebox for fittings.



INSTALLATION

Step 2: Prepare Mounting Surface

1. If applicable, use a stud finder to locate a wooden support stud. Plywood, or other flat wall surfaces capable of supporting the weight of the Wall Connector, may also be used.



2. Based on the chosen wire entry path, position the included cardboard mounting template onto the installation surface and use a bit to drill two pilot holes (one from the top row and one from the bottom row).



NOTE: When installing for rear left or rear right wire entry, select the two mounting holes that are on the opposite side of the wire entry point.



NOTE: Use a level tool with the cardboard mounting template to ensure a level installation as desired.

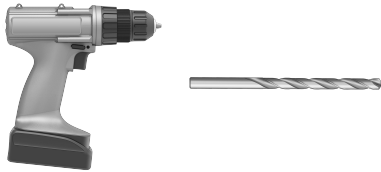

Drill bit

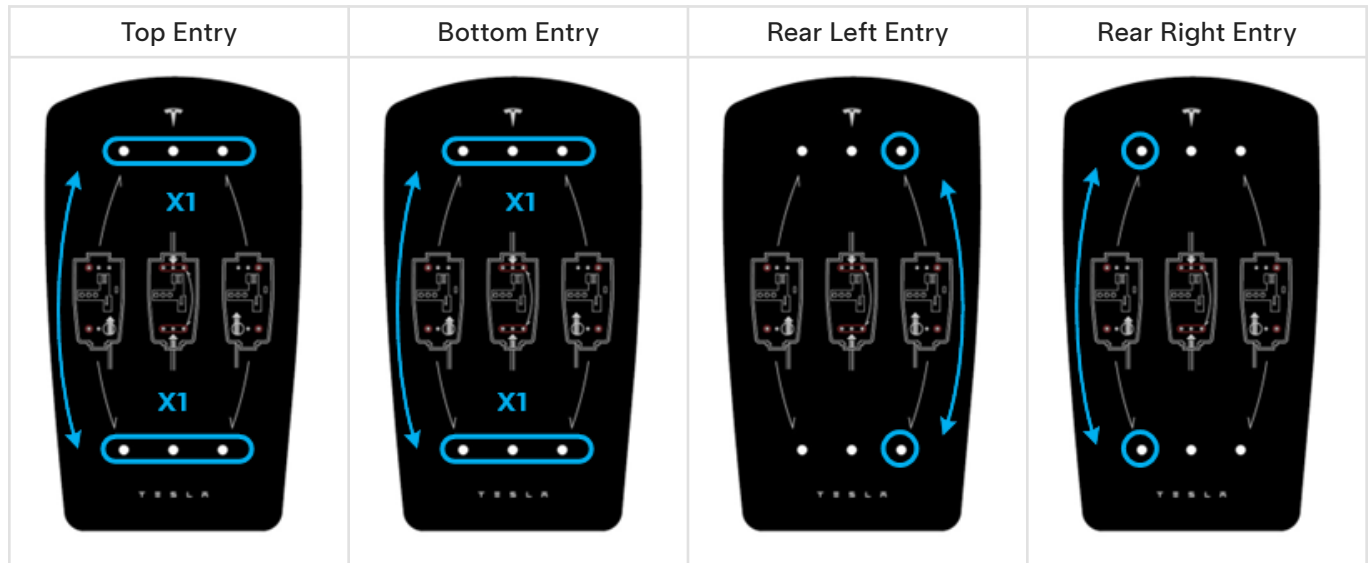



Step 3: Prepare Wirebox and Mount to Wall

1. Use a bit to drill two pilot holes into the wirebox that match the locations chosen on the cardboard mounting template.

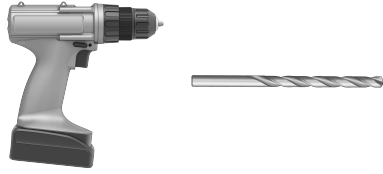

Drill bit

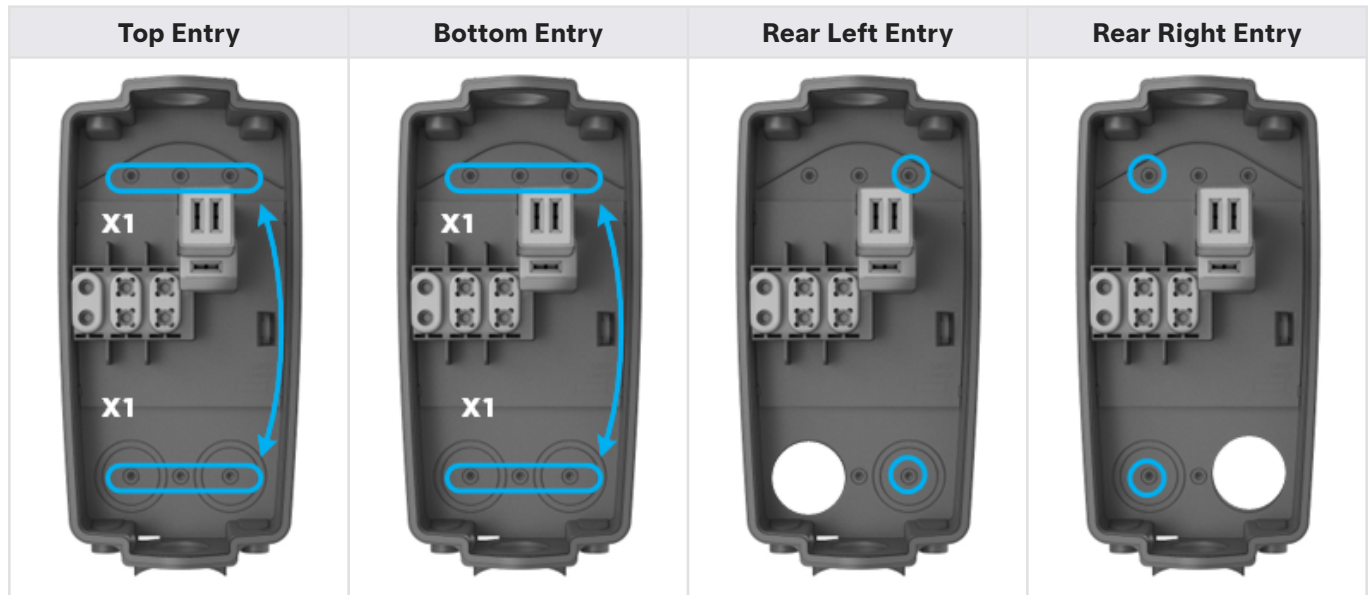

2. Attach the wirebox to the mounting location using the included 4 mm hex bit and the two included wood fastener screws.

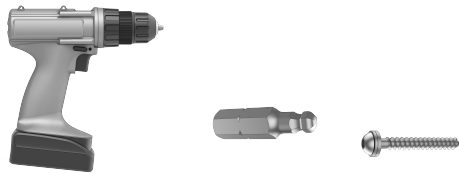

NOTE: Type 3R rating is only possible when washers have sealing gaskets. If mounting to alternate surface (such as a prefabricated pedestal), use alternate fasteners with sealing washers.



NOTE: The wood fastener screws are designed to support the weight of the entire Wall Connector, cable, and charging handle.



Step 4: Route Wiring Through Wirebox

1. Route wiring into selected entry point and through the service loop channel on the right side of the wirebox.

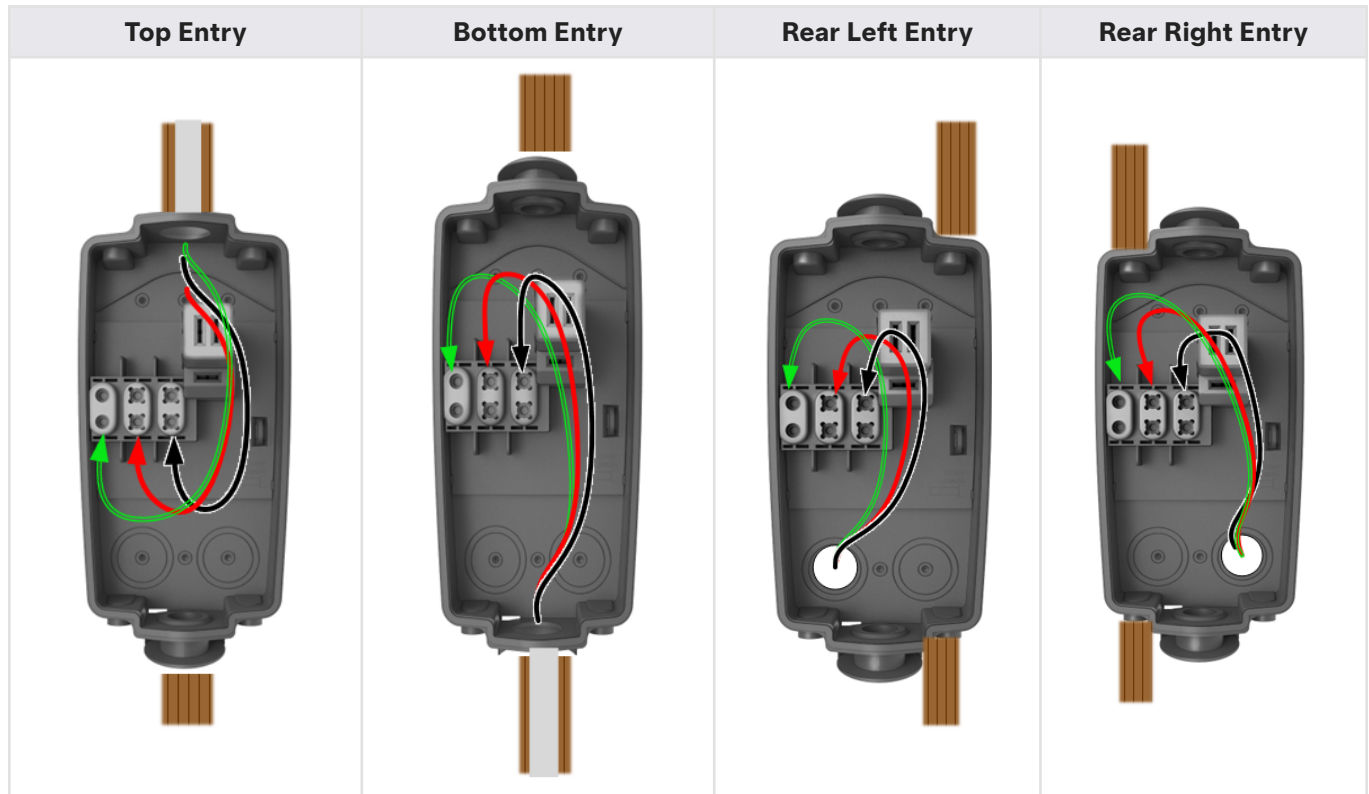

2. Use appropriate cable glands, bushings, or fittings to secure the wiring in place and protect from water and debris intrusion.



CAUTION: Ensure that bushings are in place to avoid damage to conductors and ground wire when pulled into wirebox.



CAUTION: Use copper conductors only.



NOTE: Compression-style fittings are recommended to prevent interference.



NOTE: For top or bottom wire entry, if installing fittings with a set screw, ensure that the screw is positioned to avoid interference with Wall Connector cables.



Step 5: Strip and Land Wiring

1. Strip insulation from wires , route through service channel, and land each wire in its correct terminal block.



NOTE: Terminals are bi-directional.

2. Secure the wiring in the service channel using the included zip tie.

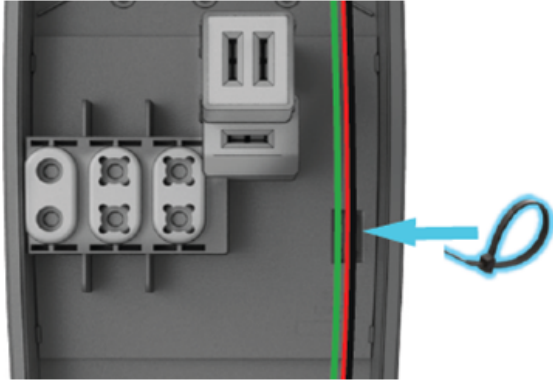

3. Use a torque driver and the included 4 mm hex bit to torque the terminal screws to 50 in lb (5.6 Nm).



NOTE: When installing Wall Connector in a split phase electrical system, use Line-to-Line instead of Line-to-Neutral.



Step 6: Attach Wall Connector to Wirebox

1. Attach the main unit to the wirebox by pushing it inward.



CAUTION: Ensure that the wiring is not pinched when attaching the wirebox.

2. Secure the main unit to the wirebox with the four included fasteners and the included 4 mm hex bit using a bit driver, applying pressure to the faceplate during the process to compress the internal seal. Firmly hand-tighten the four fasteners until they are secure.



NOTE: Do not use a power drill for this step.

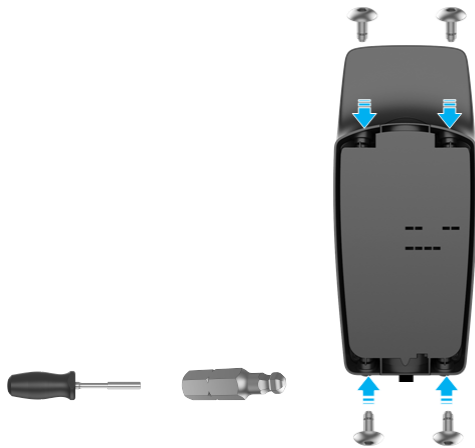



Step 7: Energize Wall Connector

1. Energize the Wall Connector by turning on the upstream circuit breaker.



NOTE: To energizing a leader/follower unit turn on the upstream circuit breaker, though multiple units will be fed by one breaker and multiple will turn on when the breaker is flipped.

There's no difference in energizing a leader/follower unit except that multiple units will be fed by 1 breaker, so multiple will turn on when the breaker is flipped.

Gen 3 Wall Connector

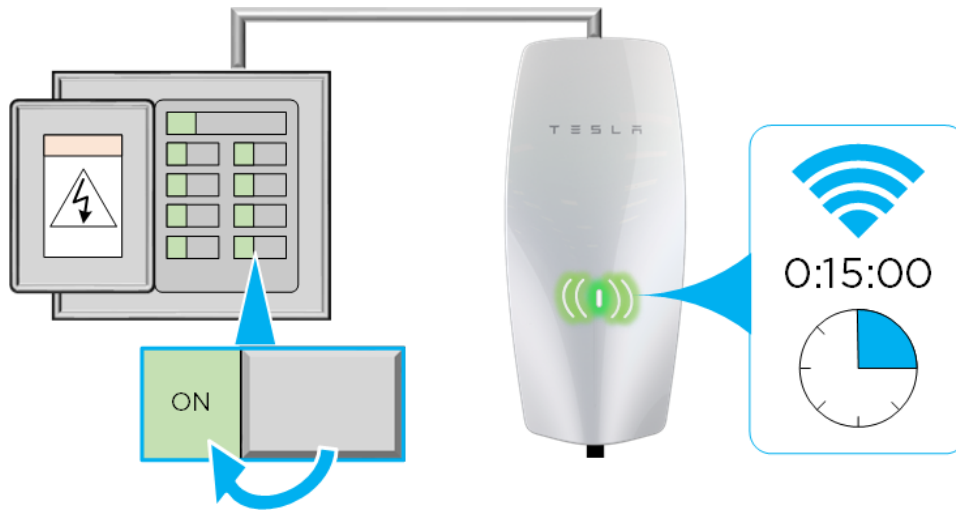

The Wall Connector's LEDs will turn on. See [Wall Connector LEDs on page 68](#).

2. Proceed with commissioning.



COMMISSIONING PROCEDURE

The commissioning process for Wall Connector enables easy configuration of circuit breaker size, Wi-Fi connectivity, and group power management options.

The Quick Start Guide is included with the Wall Connector and contains a QR code that is used to connect to Wall Connector to perform device setup.



NOTE: Ensure the Quick Start Guide is not discarded as the QR code may be required in the future!



CAUTION: Start the process only when the Wall Connector is powered on. Do not connect to any load when the face plate is separated from the main unit.

1. Using the smartphone camera, scan the QR label on the Quick Start Guide.



- o If the Tesla One app has not yet been installed, follow the prompts to install the app.
- o If the Tesla One app is already installed, ensure it has been updated to version **10.8 or greater** (select **More**, then select **Settings**, then the app version to see if an update is available).

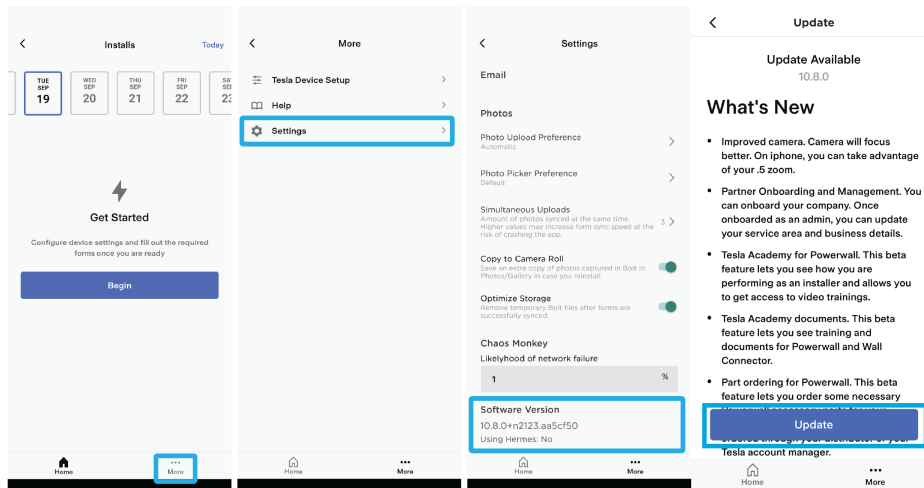

NOTE: Tesla One gets new features every week, so update frequently! The app should automatically update but it is best practice to check for new updates, and manually update when one is available.

2. Log in to Tesla One using your Tesla Partner Portal account, or select **Create Account** to create a new account.



COMMISSIONING PROCEDURE



NOTE: Apple users may be prompted to allow Tesla One to find and connect to devices on the local network. Select **Allow** or **OK**, as this is required to connect to the Wall Connector Wi-Fi network. If the prompt does not automatically appear, permission can be granted by selecting Settings > Apps > Tesla One > Local Network.

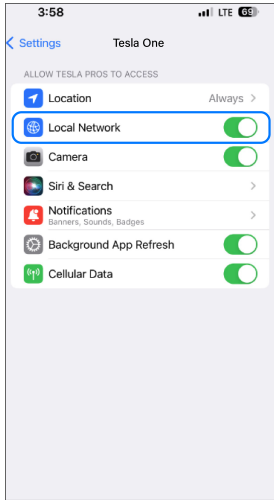

NOTE: Android users may be prompted to allow Location Consent. **Allow all the time** or **Allow only while using the app**, as this is required to allow Tesla One to find and connect to devices. If the prompt does not automatically appear, permission can be granted by selecting Settings > Apps > Tesla One > Location.

3. Select **Tesla Device Setup**, then select **Begin**.

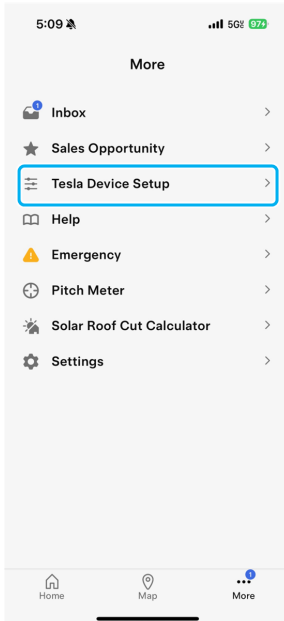

4. Select **Scan QR Code**, then use the smartphone camera to scan the QR code on the Quick Start Guide again.



COMMISSIONING PROCEDURE

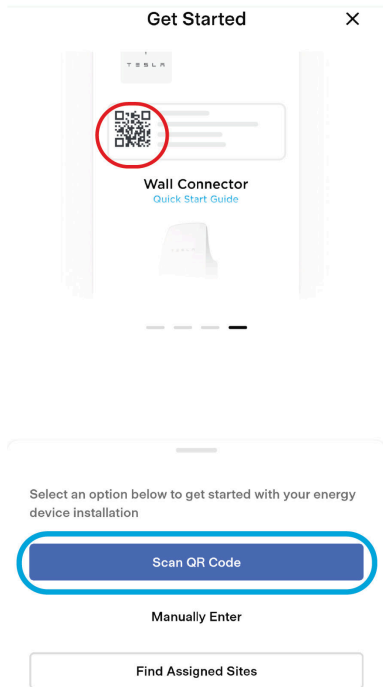

5. On the charge handle, press and hold the handle button for 5 seconds. Wait for the LED to pulse green, then select **Join**.

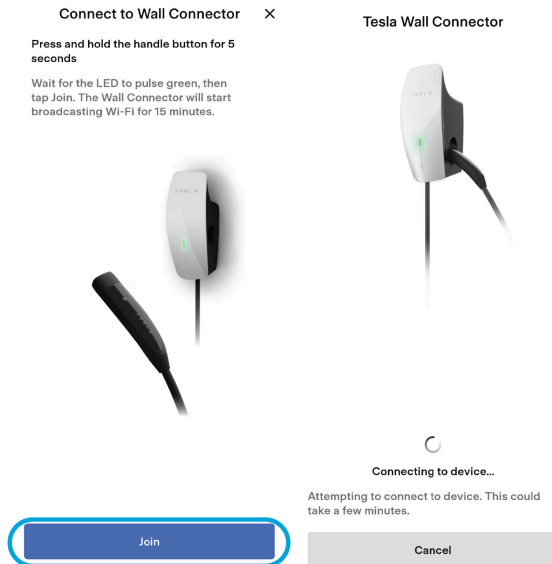

Perform Device Setup

1. Select **Installation Settings**.
2. Select the appropriate **Country**. Then select **Breaker Size (A)**.
3. Select **Wi-Fi** to connect Wall Connector to the homeowner's network. The Wall Connector can be connected to a network manually or by selecting from the available networks.
When connection is complete, Wall Connector will display Wi-Fi as connected.



COMMISSIONING PROCEDURE



NOTE: Wall Connector is only compatible with 2.4 GHz networks.

Software Updates

1. Select **Software Update** to ensure the latest software is installed.
2. Select **Update** if a software update is available.

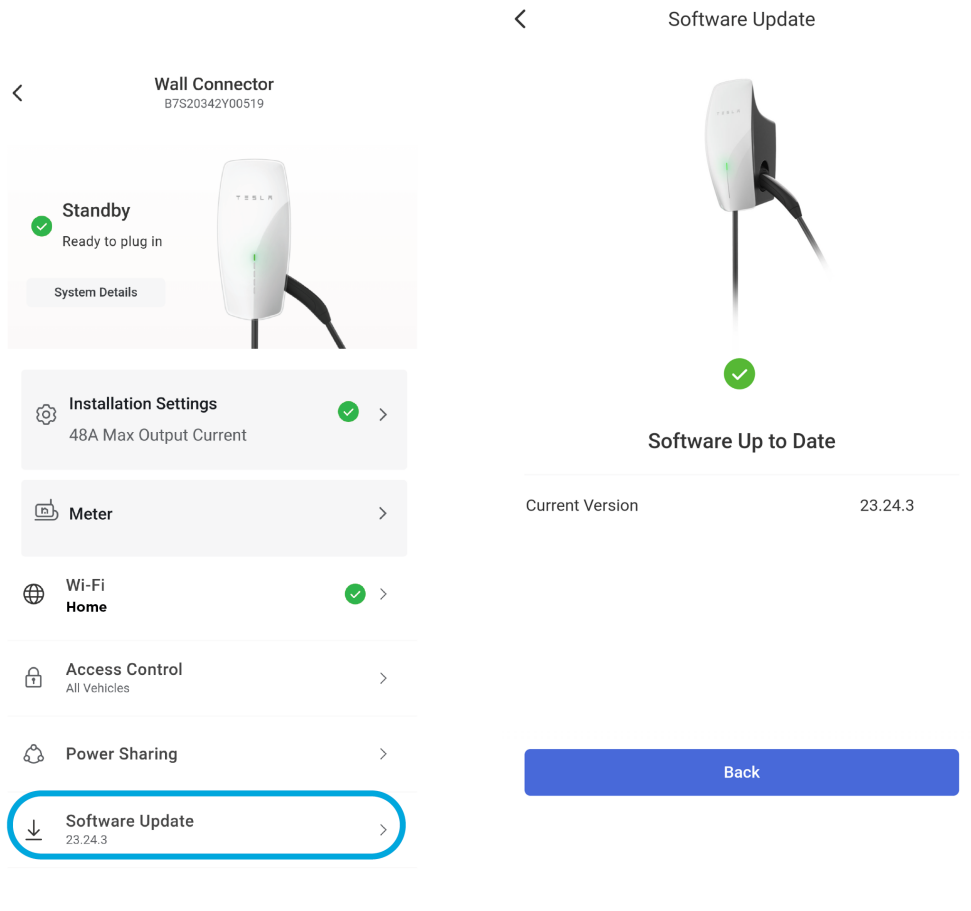

Complete Registration

Installer Registration

Installer registration is an important step for tracking install quality, and it allows the installer (and partner(s) if applicable) to view the site in Powerhub.

 **NOTE:** The site is only created in Powerhub **after** customer registration is completed. Installer registration allows the installing company to view the site in Powerhub, but customer registration must be completed for the site to exist in Powerhub.

 **NOTE:** Once installer registration has been completed, it cannot be changed in Tesla One and instead must be updated by Install Support.

To complete installer registration:

1. Select **Registration > Installer Info** and enter your contact information.



COMMISSIONING PROCEDURE

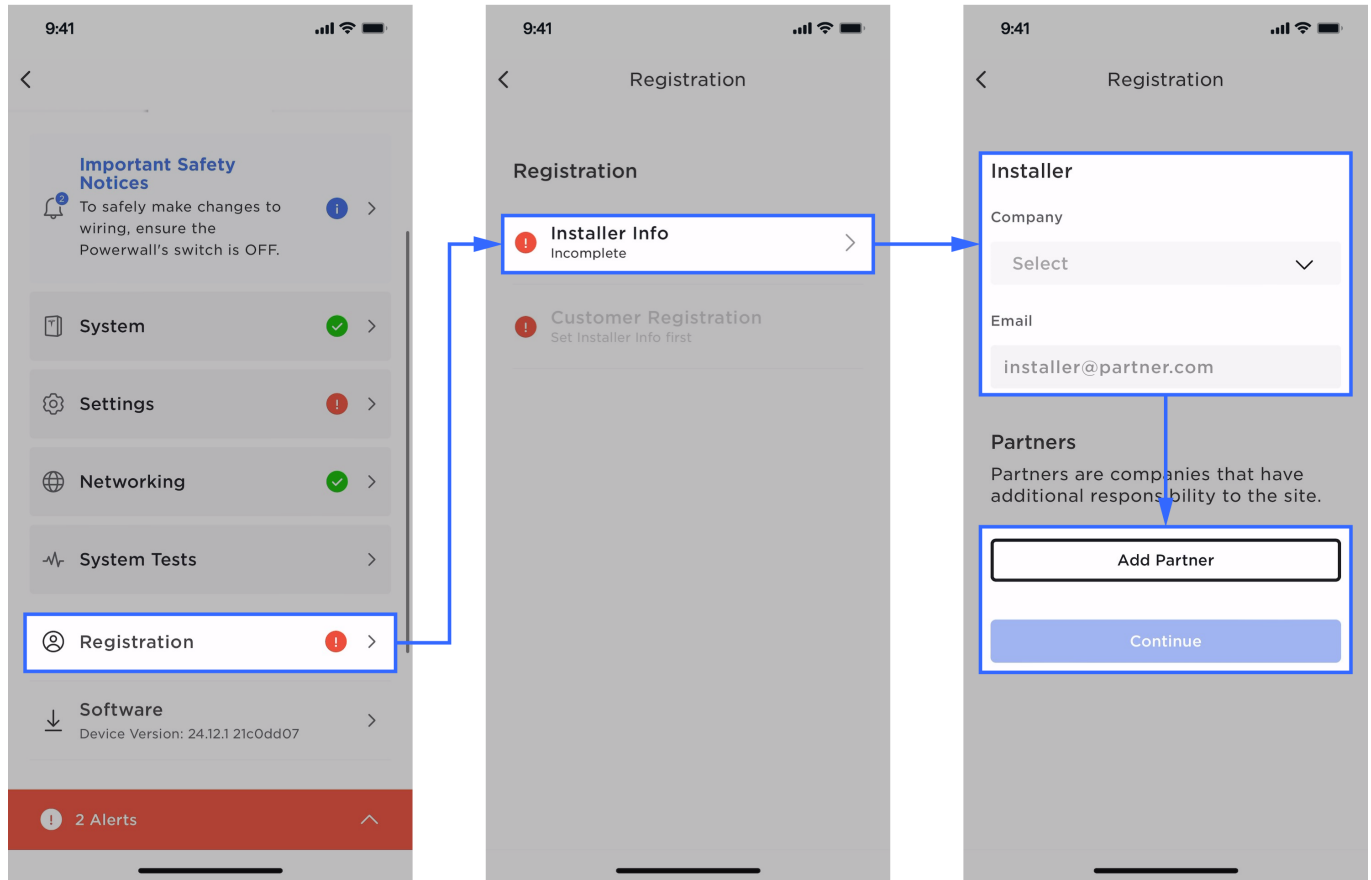

- a. In the **Company Name** field, verify that the name of the company performing the installation has automatically been filled in. If the company name is not present or is not correct, search for your company to select it.

 **NOTE:**

- The **Company Name** is the field that links a partner to a site, meaning this is the field that allows a company to view the site in Powerhub.
- If you are not a Tesla Certified Installer, please select **Unknown** for the company name field, and then manually type your company name, if applicable.

- b. In the **Email** field, leave the email address of the installer completing the installation. This email address is used to track Tesla Academy training completion and the Pro Score inside Tesla One.

2. To add a partner installer company:

- a. Select **Add Partner** and search for the partner name to select it.



COMMISSIONING PROCEDURE

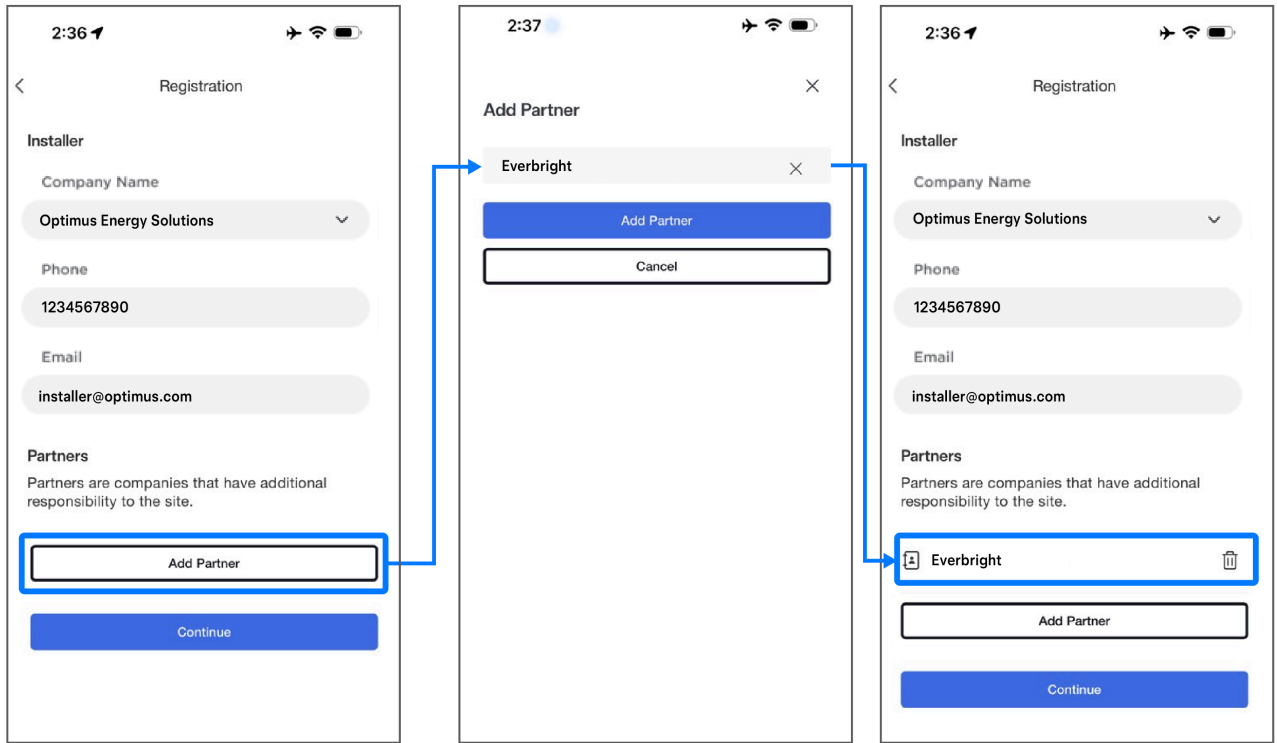

b. Repeat this step if needed (up to two partner companies can be added).

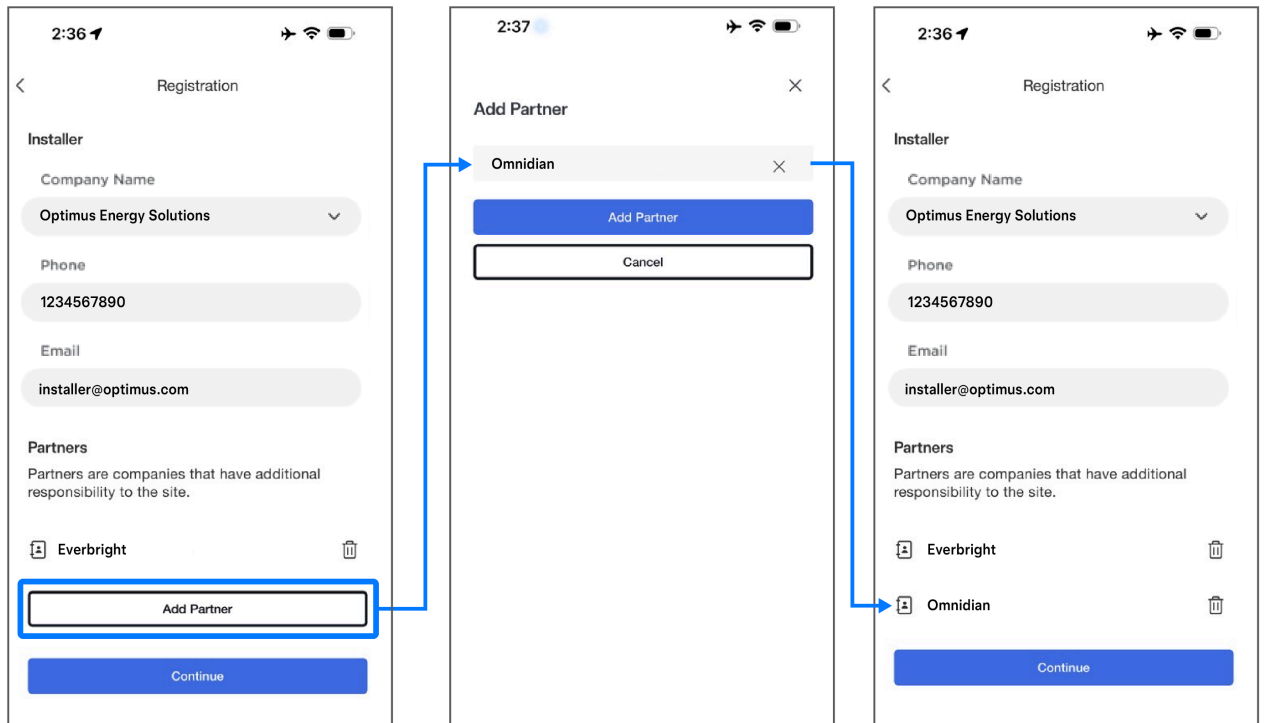

NOTE: This feature enables another company or entity to access the site in Powerhub. For instance, if another company is performing the installation, sold the system, owns the system, or distributes the hardware in region, they can be given Powerhub access to the site this way.



COMMISSIONING PROCEDURE



NOTE: If the site is not shared with partner companies during device setup, it can be shared using Powerhub. See [Site Sharing in the Residential Powerhub User Manual](#) for instructions to share the site with partners.

3. Select **Continue** to proceed to the customer registration.

Site Visibility in Powerhub

Tesla products appear in the Powerhub Fleet Monitoring Portal after Customer Registration is completed, and if the *Company Name* was present during commissioning per the above steps.

If a site is not visible in Powerhub:

1. Make sure the site was registered, meaning the customer can see it in their Tesla App.
2. Contact the company that installed the system (or a partner company with site sharing capability) and ask them to share the site in Powerhub. See [Site Sharing in the Residential Powerhub User Manual](#) for more information.



COMMISSIONING PROCEDURE

Customer Registration

Customer registration allows the customer to view their system in the Tesla app, and the customer's product warranty is activated upon registration.

Tesla has two paths for customer registration:

- **Option 1 (Installer-Led Registration, preferred):**
 1. Select **Enter Customer Info**.
 2. Enter the customer's email address, then select the **Next** button.
 3. Complete the registration form.

 **NOTE:** The customer email address entered during registration is the link between the product and the customer's Tesla account. **Please ensure that the email address is entered correctly and is the one used by the customer for their Tesla account.**

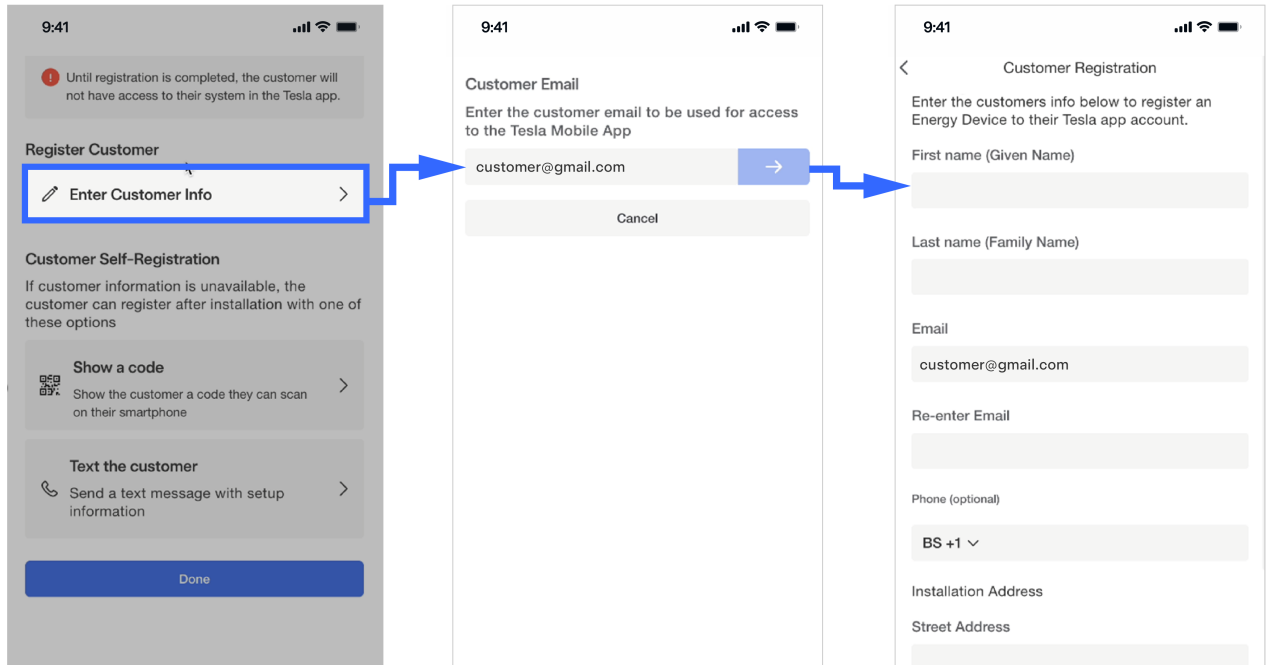

- **Option 2 (Customer-Led Registration):** If the customer is available, select **Show a code** or **Text the customer** to allow the customer to enter their information. Both of these methods open the Tesla app to the *Add Products* page; the customer can also navigate to *Add Products* manually.



COMMISSIONING PROCEDURE

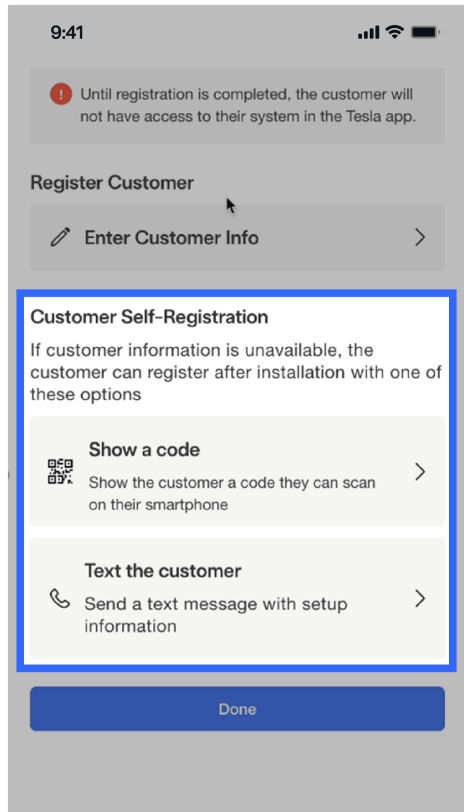

 **NOTE:** If customer registration is not completed, the customer will not have access to the system in the mobile app. Ensure customer registration is completed!

Multi-Product Customer Registration

Each Wall Connector is separate, meaning each must be commissioned and registered individually. Failure to fully register **all** products will result in loss of Powerhub visibility, loss of customer app visibility, and unactivated warranties.

If a customer has multiple Tesla devices (Wall Connector(s) and/or Powerwall), all devices can be registered to the same site for simplified viewing in Powerhub (for the installer) and the Tesla app (for the customer).

 **NOTE:**

- This feature can be used in the following installation scenarios:
 - Adding multiple Wall Connectors to a single site
 - Adding Wall Connector to a Powerwall site (or vice versa)
- For complex edge cases, Tesla Support remains available to correct registration issues after the registration process is completed

Options for registering multiple devices to a single site:

- **Option 1 (Installer registers devices, preferred):**
 1. Register one of the devices.
 2. For each subsequent device:
 - a. Connect to the device in Tesla One and, during the registration step, enter the customer's email address.



COMMISSIONING PROCEDURE

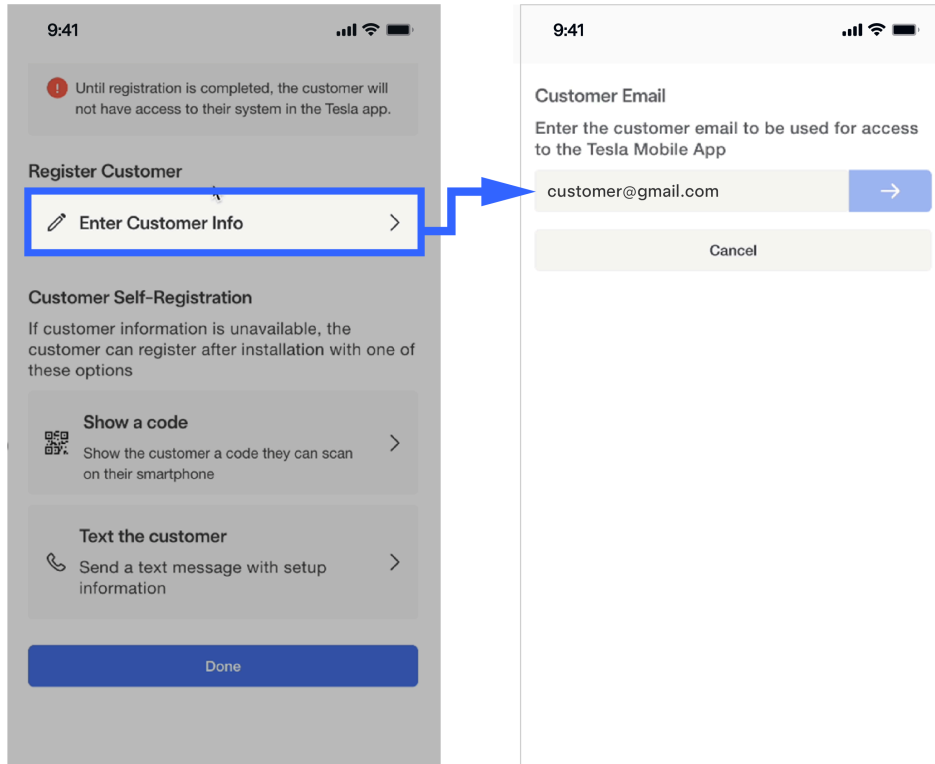

- b. If the first device was registered within the last 24 hours by the same installer (using the same mobile device), the **Add to Recent Site** option will appear with the customer's registration information. Select this option.

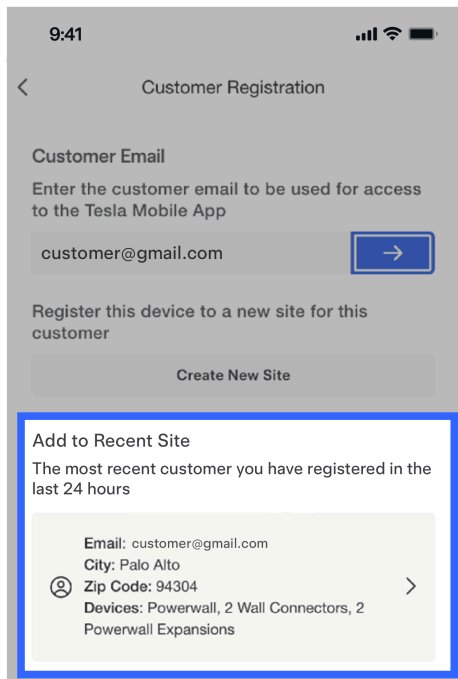

- c. If the **Add to Recent Site** option is not available, select the **Next** button.
d. Select the existing site.



NOTE: Existing sites belonging to the same customer email address **and** the installer's Powerhub instance will be displayed.



COMMISSIONING PROCEDURE

e. Select **Register**.

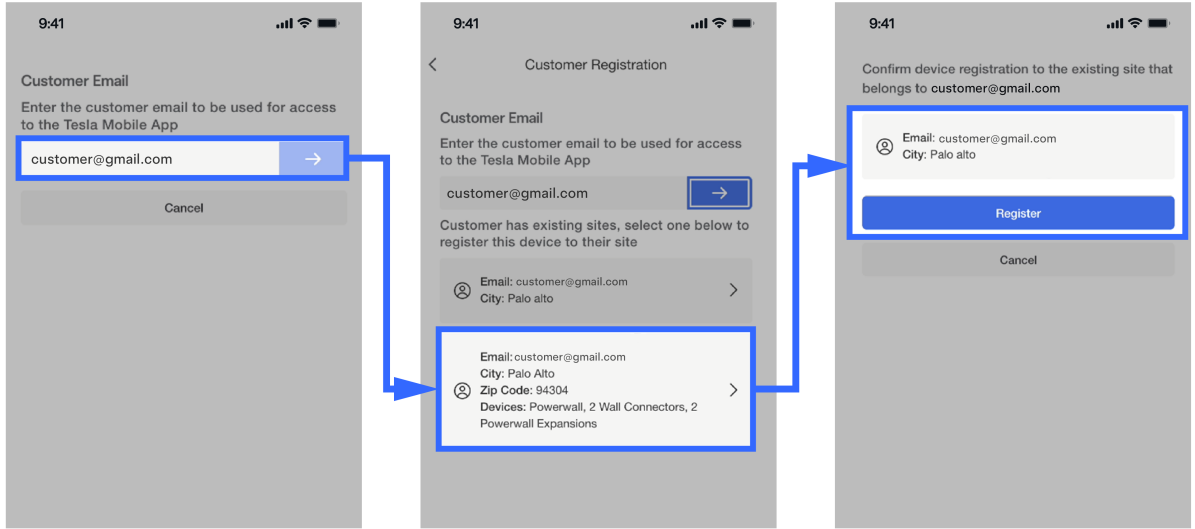

- **Option 2 (Customer registers devices):** Customers can register additional devices to their existing account using the [Add Product](#) page in the Tesla app.

If either of these options fails for any reason, submit an [Energy Service Portal \(ESP\) ticket](#) using your [Partner Portal](#) credentials to have them manually register the additional devices. Provide the following information:

1. Customer Name
2. Customer Address
3. Customer Email (associated with their Tesla Account, matching what was entered by the installer)
4. Already registered equipment DIN (Device Identification Number: Part Number & Serial Number)
5. Additional DINs that need to be registered and added to the existing Site

Address Alerts

The Alerts tray is displayed at the bottom of the page if any alerts are present, and is a shortcut for the installer to address important issues. The Alerts tray displays critical errors that the installer must take action on.



COMMISSIONING PROCEDURE

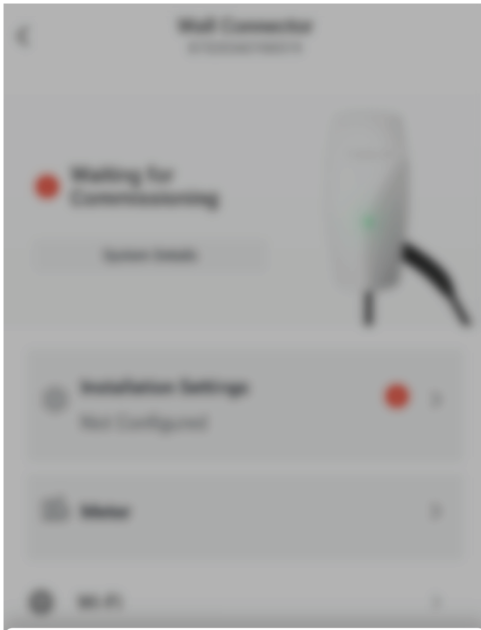

1 Alert ×

! Installation Settings Not Configured
Country and Max Current Limit is not yet configured and is required to complete installation.

Alert Types

Some alerts are used to help explain what the system is doing:

- Software Update

Some alerts are used to indicate an issue the installer needs to address:

- Installation settings not configured



COMMISSIONING PROCEDURE

Alert Icons

Icon	Name	Description
	Process	The system is carrying out a process; wait for it to complete
	Success	This task has been completed successfully
	Warning	There may be an issue; the installer should review
	Error	There is an issue that will prevent the system from functioning; action is required by the installer

System Details

1. Select **System Details** to access more information about the Wall Connector System.

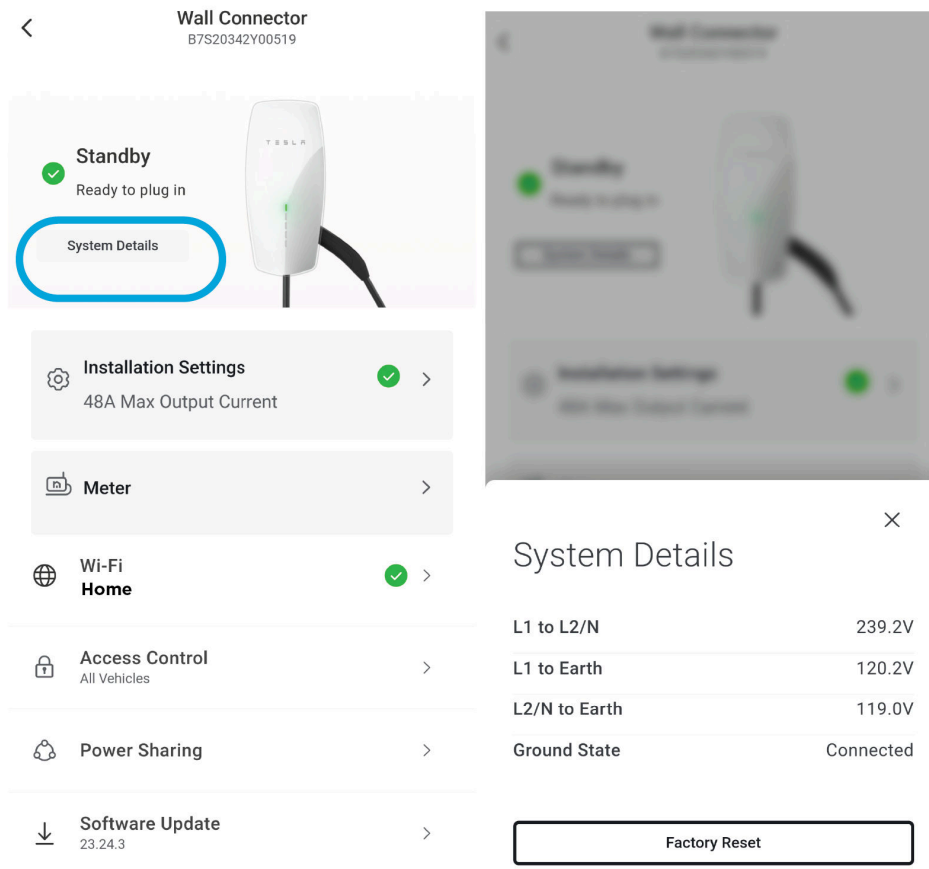

Optional: Access Controls

1. Select **Access Controls** to configure which specific vehicles can access Wall Connector.
2. From the *Access Control* menu, select the level of access control as determined by the customer:



COMMISSIONING PROCEDURE

- **All Vehicles:** default option, any vehicle can charge from this Wall Connector.
 - **Only Teslas:** any Tesla can charge from this Wall Connector.
 - **Authorized Teslas Only:** only Teslas configured in device setup or Tesla app can charge from this Wall Connector.
 - **Compatibility Mode:** This option allows Wall Connector to be compatible with older generation vehicles. Use it only if you experience faults with your Wall Connector and your electric vehicle. Note that you will lose some software functionality in utilizing this mode.
3. If configuring Authorized Teslas Only, select **Add** to enable access for new vehicles. Enter the VIN(s) of the vehicle(s) the customer would like to authorize. The customer can also add vehicles in the Tesla app.

Optional: Dynamic Power Management

Dynamic Power Management enables Wall Connector to dynamically adjust EV charging power based on live readings of the overall load in the panel. An energy meter is installed to MONITOR live current in the panel; when panel loads are reduced, Wall Connector is able to increase charging current up to a limit set by the installer.

 **NOTE:** As described in the [Wall Connector Application Note on Dynamic Power Management](#), Wall Connector should be installed with a 60A circuit breaker for maximum power output; if there is not enough room for the recommended breaker size in the electrical panel, a smaller breaker can be installed with a lower amperage configuration (see the application note for more information).

1. Once connected, the Remote Energy Meter will automatically be detected. Select **Meter** to configure CTs and set the Max Conductor Limit.

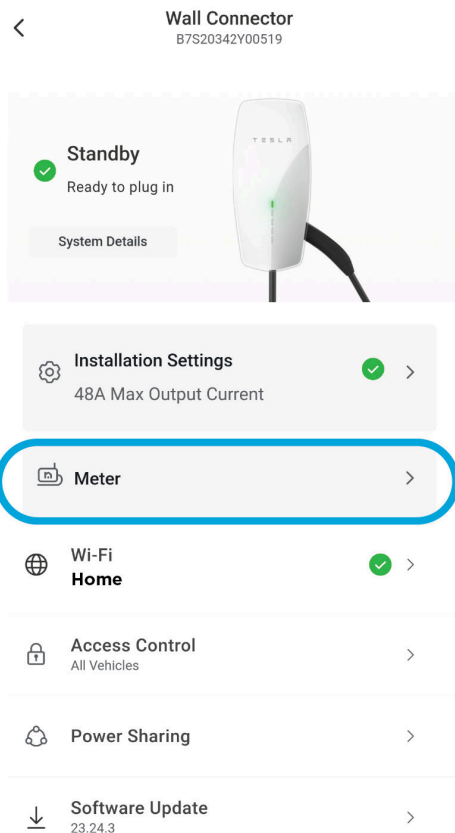



COMMISSIONING PROCEDURE



NOTE: The Remote Energy Meter has four CT ports, with the following voltage references:

- CT1: L1
- CT2: L2
- CT3:
- CT4: L1

2. Select the energy meter to configure the CTs.

3. For each of the connected CTs, select the CT and set the **Location** to **Conductor**.

The image displays two screenshots from a mobile application. The left screenshot shows the 'Meter' configuration screen. At the top, there is a back arrow and the title 'Meter'. Below this is the 'Meter Configuration' section, which contains a button labeled 'Neurio · VAH4635AB2553 Tap to Configure' with a red information icon and a right-pointing arrow. Below this is the 'Max Conductor Limit' section, which includes a text description: 'Wall Connector will limit charging to prevent exceeding the Max Conductor Limit.' and a text input field containing the number '6' and the unit 'A'. Below the input field is a warning message: 'Overcurrent protection is your responsibility'. At the bottom is a blue 'Back' button.

The right screenshot shows the 'Neurio Meter' configuration screen for the device VAH4635AB2553, which is marked as 'Connected'. At the top, there is a back arrow and the title 'Neurio Meter' with the ID '15451'. Below this is a table of CT configurations:

CT	Location	Current
A 1	Conductor	0.717A
B 2	Conductor	0.717A
B 3	None	
A 4	None	

Below the table are sections for 'Current Transformer 1' (14W (0.7A) import) and 'Current Transformer 2'. The 'Current Transformer 2' section has a red box around the 'Location' dropdown menu, which is set to 'Conductor'. Below this are fields for 'Current' (0.717A), 'Power' (14.292W), and a 'Flip' checkbox. At the bottom are sections for 'Current Transformer 3' and 'Current Transformer 4'. At the bottom of the screen is a blue 'Back' button.

4. On the **Meter** screen, set the **Max Conductor Limit**. This value should be 80% of the electrical panel's rated limit.



COMMISSIONING PROCEDURE

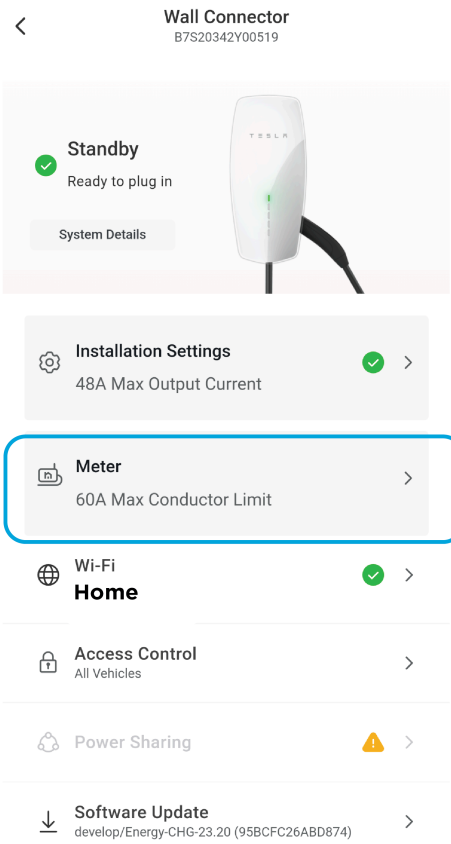
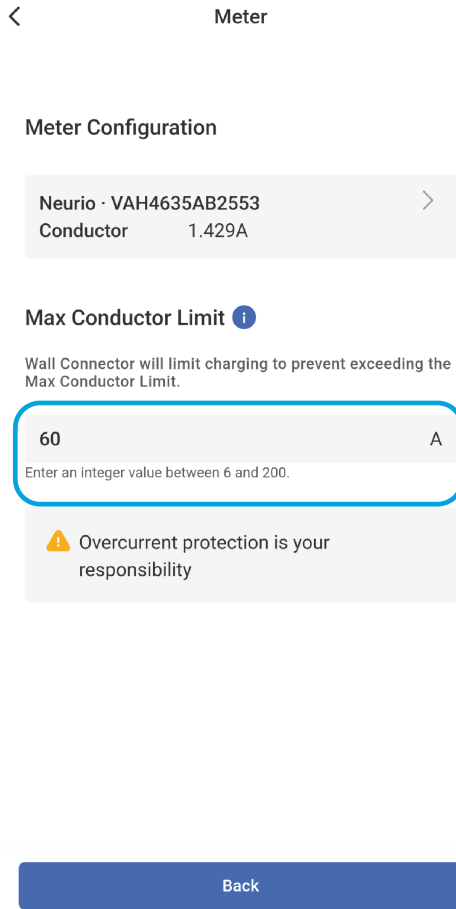

See the [Wall Connector Application Note on Dynamic Power Management](#) for instructions to test the system and troubleshoot as needed.

Optional: Group Power Management

Power sharing can only be done in a group of six wall connectors (one leader + five followers). Finish commissioning the followers before commissioning the leader. Additionally, make sure that all the followers have a good line of sight to the leader. For more information, see [Group Power Management on page 57](#).

1. Select **Power Sharing** to connect additional Wall Connectors.
2. Toggle off **Power Sharing** to make settings adjustments.
3. To add a new Wall Connector, select **Scan QR Code** then scan the Wi-Fi QR code on the new Wall Connector's Quick Start Guide.
4. Select **Add Follower** to add the new Wall Connector.



COMMISSIONING PROCEDURE

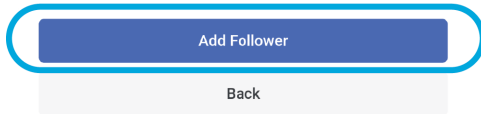
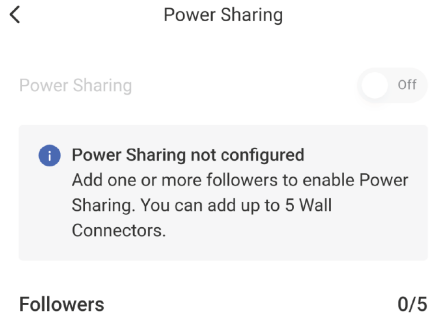

5. Select **Done** once the leader is reconnected and the follower has successfully been added.
6. Enable the power sharing network.

Program Network Limit

1. Select **Power Sharing Settings** to program a network limit.
2. Enter the appropriate network limit:



NOTE: This is the maximum total current a power sharing network is allowed to consume in amps. This represents the continuous current which the network will not exceed. An electrician will need to determine the correct amount of amperage and confirm that the load center has appropriate overcurrent protection.

Expected Behaviors

- SSID access point of all Leader Wall Connectors in a power sharing network will continue to broadcast.
- Removing a Wall Connector from a network will temporarily set that device's max output to 6 amps. Cycle circuit breaker to reset Wall Connector to original configuration setting.
- Leader Wall Connector will share site Wi-Fi with follower Wall Connectors.



Operating and Error States

Operating States

Ready: Wall Connector is ready to charge.

Charging: Connected to the internet and charging the car.

Unplugged: Connected to internet but not connected to car.

Waiting for vehicle: Charger is plugged in, and a charge session needs to be initiated in the vehicle or through the app.

Error States

Critical fault: Needs to be monitored. If it lasts for over 3 days, call Tesla Service.

Non-critical fault: Charging blocked due to authentication error, call Tesla Service.

Offline: Wall Connector does not have good connectivity and cannot connect to Tesla Servers. Contact your Tesla Certified Installer.

Error Codes

Error	Solution
Device is already registered on the same site and shows a warning.	Refresh the device list.
Device is already registered to a different site.	Remove from Warp and try to register again/Flag to Tesla team members.
Firmware is not up to date to minimum 22.33.1	Update firmware.
Request ID cannot be found in error logs.	Send a ticket to the Engineering team.



COMMISSIONING PROCEDURE

Device Registration

Register the Wall Connector to the user's account to enable full app functionality and benefits.

 **NOTE:** Ensure you are using the latest version (12.41.0 and later) of the Setup app before registering the Wall Connector to the user's account.

1. Complete the configuration of the **Installation Settings**.
2. Select **Registration**.
 - a. In the drop down menu, select **Commercial** or **Residential** as the installation site type.

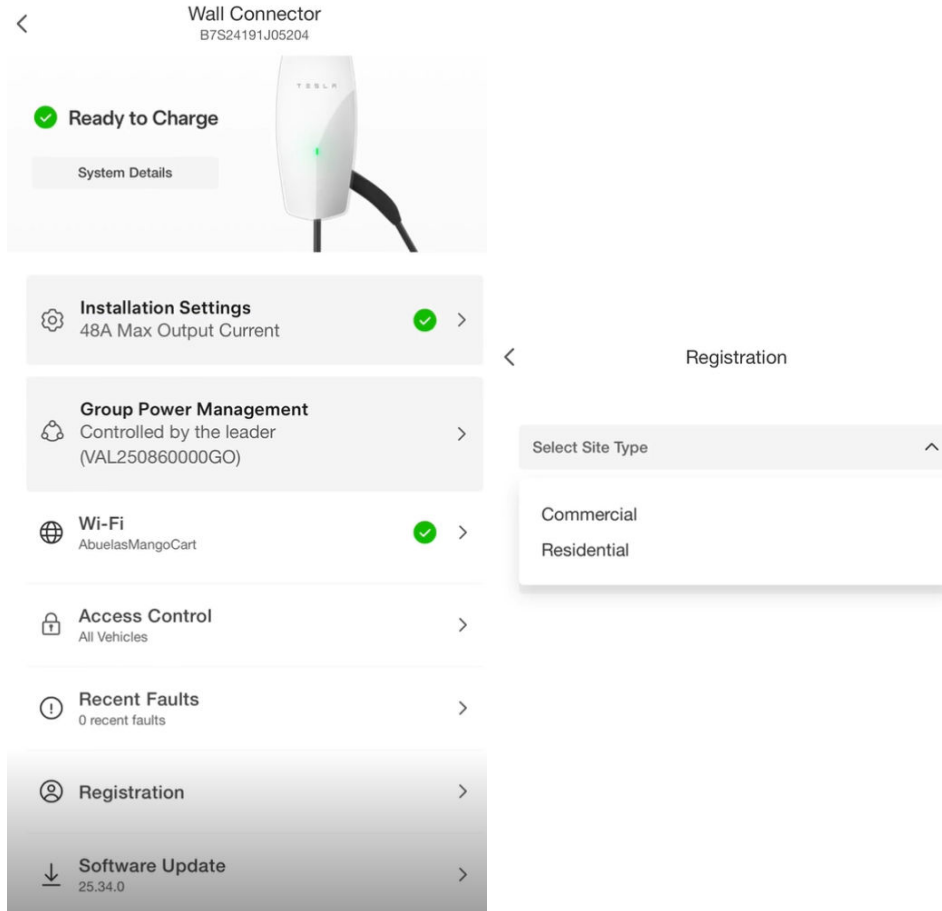

3. Register the customer by selecting **Enter Customer Info**.



COMMISSIONING PROCEDURE

< Customer Registration

 Until registration is completed, the customer will not have access to their system in the Tesla app.

Register Customer

 Enter Customer Info >

 Lead-Share Customers >

Customer Self-Registration

If customer information is unavailable, the customer can register after installation with one of these options

 **Show a code** >
Show the customer a code they can scan on their smartphone

Done

a. Enter the customer's email address.

< Customer Registration

Customer Email

Enter the customer email to be used for access to the Tesla Mobile App



Cancel

b. Enter the customer's first and last name, email address, phone number, and installation address.



COMMISSIONING PROCEDURE

< Customer Registration

Enter the customers info below to register an Energy Device to their Tesla app account.

First name (Given Name)

Last name (Family Name)

Email

Re-enter Email

Phone (optional)

Installation Address

Street Address

City

State/Province/Region(optional)

c. Select **Continue**.

4. Complete the registration:

a. In the **Confirm the Installation Company** field, verify that the name of the company performing the installation has automatically been filled in. If the company name is not present or is not correct, search for your company to select it.

 **NOTE:** The **Company Name** is the field that links a partner to a site, meaning this is the field that allows a company to view the site in Powerhub.

b. To add a partner installer company, select **Add Partner** and search for the partner name to select it.

c. Confirm the customer's email and select **Submit Registration**.



COMMISSIONING PROCEDURE

< Customer Registration

Confirm the Installation Company

Xero Solar ×

Partners
Partners are companies that have additional responsibility to the site.

Add Partner

Confirm the Customer Email
Confirm the customer's email below. This can't be changed after submitting.

Bender.rodriguez@gmail.com

Submit Registration

Edit

d. Registration is complete.

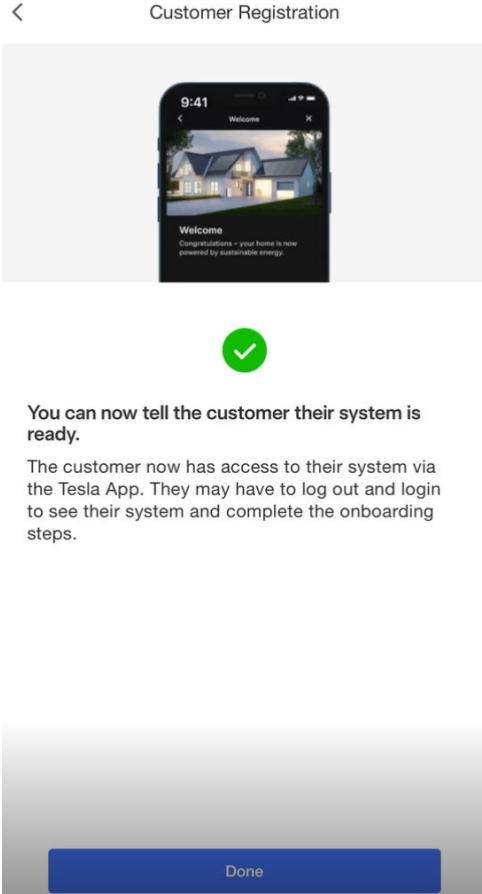

You can now tell the customer their system is ready.

The customer now has access to their system via the Tesla App. They may have to log out and login to see their system and complete the onboarding steps.



STATIC POWER MANAGEMENT

Static Power Management allows your installer to select from several different power levels when your Wall Connector is installed. Based on the available power in your electrical panel, the installer will utilize the [best power level for your Wall Connector to match your electrical system](#).

How It Works

Static Power Management sets a maximum charge for your Wall Connector that works with your home electrical system. This maximum charge rate will be constant and will not adjust for any reason.

Why It's Useful

This feature allows you to install and use Wall Connector with whatever existing power is available at your home, without needing to purchase any additional hardware. Even at a lower power level, most people can charge enough overnight to meet their daily driving needs.

Setting up Static Power Management in the Tesla One app

Your installer will configure Static Power Management when commissioning your Wall Connector by following the steps below:

1. Download and open the [Tesla One app](#); connect your device to the Wall Connector.



STATIC POWER MANAGEMENT

2. Select the 'Installation Settings' card on the commissioning home screen.
3. Choose 'Country' and 'Breaker Size (A).' Click 'Done.'



DYNAMIC POWER MANAGEMENT

Dynamic Power Management adjusts charge rate in real-time based on the available power in your electrical panel. This means your charge rate will always be the fastest possible, while ensuring that total power being drawn from your panel is within safe limits.

 **NOTE:** Dynamic Power Management requires the purchase and installation of a Tesla-approved power meter, sold separately from the Wall Connector. Currently, these meters are available [for purchase online](#) or through a [Tesla Certified Installer](#).

How It Works

Using a Tesla-approved power meter, Dynamic Power Management continuously monitors the available power in your panel and adjusts your Wall Connector charge rate based on electrical usage in your home. So when your home is using more power—for example, when you have a dryer and a water heater running—your vehicle will charge more slowly. But when your home is using less power—for example, at night—your vehicle will charge more quickly.

Why It's Useful

This feature allows you to get the maximum charge rate of your Wall Connector while avoiding electrical upgrades. This is ideal for homes or parking spaces with limited power.

Setting up Dynamic Power Management in the Tesla One app

Your Tesla Certified Installer will configure Dynamic Power Management when commissioning your Wall Connector by following the steps below:

1. Install the Wall Connector and run a minimum #22 gauge shielded twisted pair communication wire from the electrical panel to your Wall Connector. In some cases, you can install this communication wire in the same conduit as the wires powering your Wall Connector.
2. Install the power meter and Current Transformers (CTS) inside of your electrical panel.
3. Open the [Tesla One app](#) and connect your device to the Wall Connector.
4. Select the 'Meter' card in the commissioning main screen.



DYNAMIC POWER MANAGEMENT

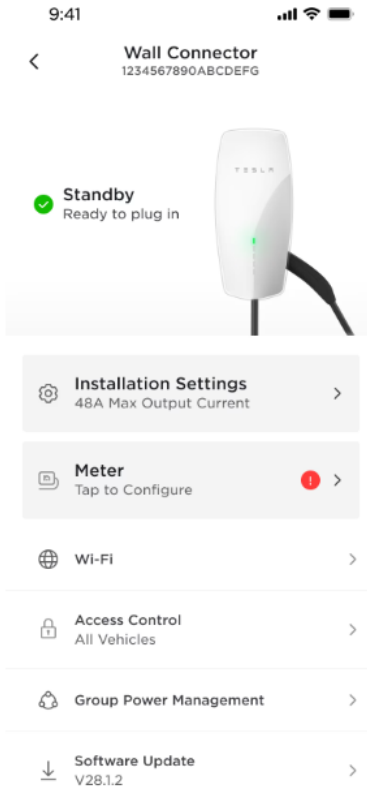

5. While on the Meter screen, select the card on top to configure the meter.

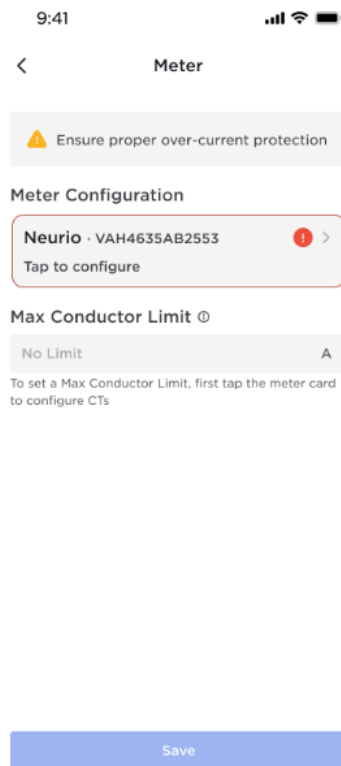

6. Set Current Transformer 1 and Current Transformer 2 as 'Conductor.'



DYNAMIC POWER MANAGEMENT

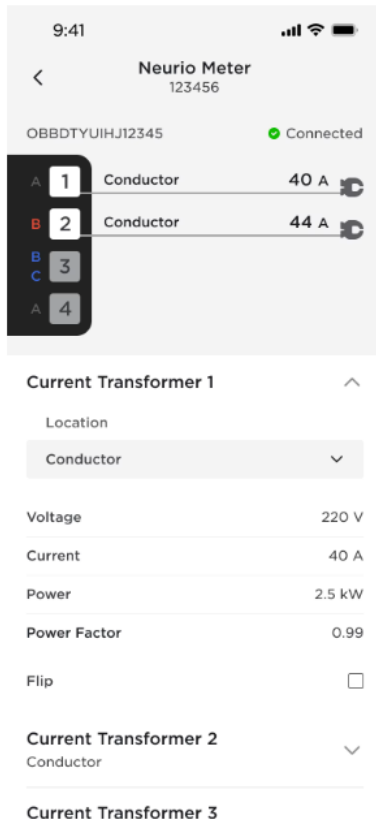

7. Back on the main Meter page, set the max conductor limit.



NOTE: This value should be 80% of the panel supply conductors or main disconnect rating (whichever is lower). For example, a 100 amp main disconnect = 80 amp max conductor limit.



GROUP POWER MANAGEMENT

Group Power Management Overview

The firmware-based group power management feature enables up to 6 Wall Connectors installed at the same site to intelligently share the site's total available power via unit-to-unit Wi-Fi. This minimizes the need for many residential and commercial applications to have specific electrical upgrades for concurrent multi-vehicle charging.

During the commissioning process,

- Wall Connectors are allocated to individual or shared branch circuits (up to 60 amps)
- Total power is allocated to the group of linked Wall Connectors

 **NOTE:** For instructions to commission Wall Connectors in a group power management network, see [Gen 3 Wall Connector Group Power Management](#).

Total current output of Wall Connectors that are grouped will never exceed the site's total allocated power.

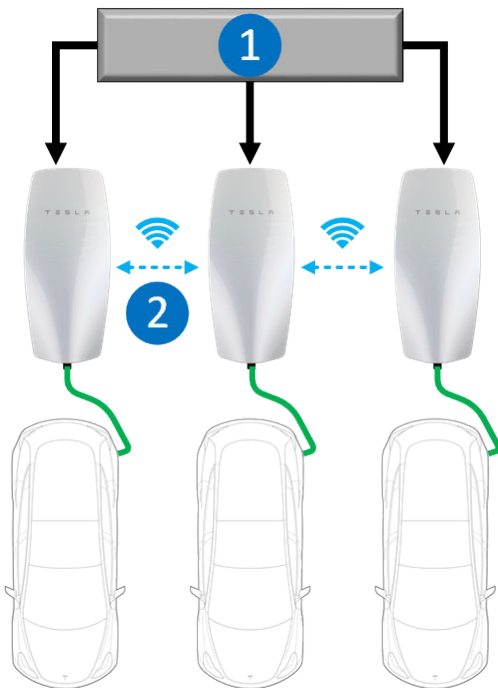

1. AC feed (service panel)
2. Group Power Management via Wi-Fi communication



Breaker and Branch Circuit Setup

Group power management circuits may be installed in an electrical panel that supports other loads. If space is limited or the main power supply is far from the Wall Connectors, installing a dedicated load center may be prudent.

See below for examples of Wall Connector group power management diagrams (one with sub-panel and one without). Each individual Wall Connector in below examples is capable of providing 48 amps when it is the only one in use. As more Wall Connectors begin plugging into vehicles, the system will automatically distribute power based on the total power allocated to the site.

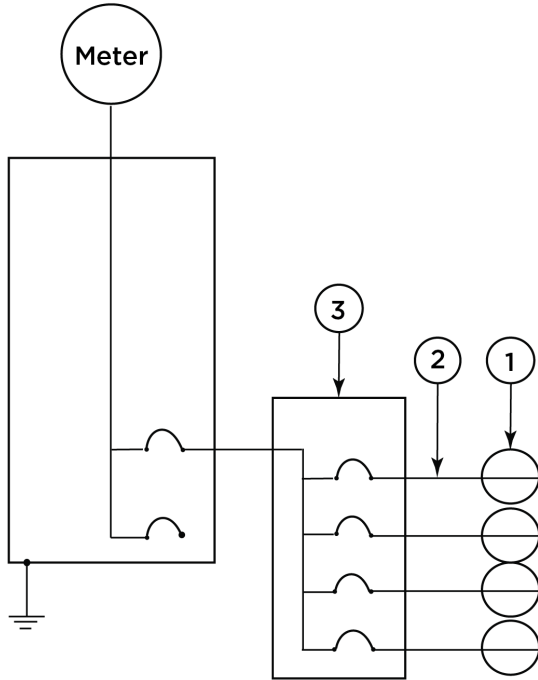

Table 3. Group Power Management with Sub-Panel

Item	Description
1	Wall Connector
2	60A branch circuit
3	100A sub-panel/feeder breaker



GROUP POWER MANAGEMENT

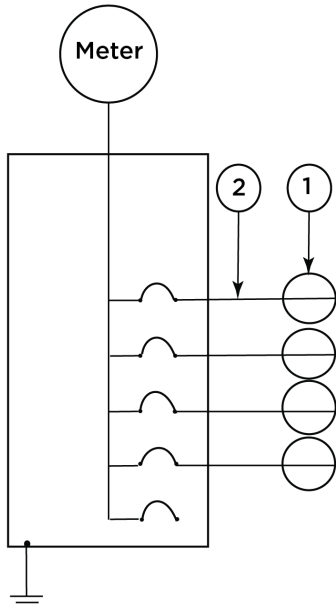

Table 4. Group Power Management without Sub-Panel

Item	Description
1	Wall Connector
2	60A branch circuit



Considerations for Group Power Management

Wall Connector group power management is achieved wirelessly.

For optimal performance, Wall Connectors within a group power management network should be installed within view of each other whenever possible.

 **NOTE:** Line of sight is recommended but not required. Wireless communication is capable of reaching around concrete corners but network range may degrade as a result.

Avoid placing Wall Connectors on opposite sides of concrete, masonry, metal studs, and other physical obstructions that would impede Wi-Fi signal strength.

 **NOTE:** If a mobile device is able to connect to the Leader Wall Connector Wi-Fi, it is a good indication that the Follower Wall Connector will also be able to connect.

Calculating Group Power Management Requirements for Existing Systems

To calculate power supply requirements per number of Wall Connectors for existing electrical systems, use the following equation:

Available continuous amperage:	Number of Wall Connectors:	Max amperage output per Wall Connector when 100% utilized:
_____	_____	_____
_____ ÷ _____ =		_____

 **NOTE:** Maximum number of Wall Connectors for group power management is 6.

 **NOTE:** When calculating maximum amperage per Wall Connector, 100% utilization must be greater than 6 amps for group power management operation. If maximum amperage is greater than 48 amps, group power management is not necessary.

For large scale sites, consider expected parking time in relation to a 100% utilization rate.

Expected Park Time (hours)	Examples	Recommended Amperage per wall Connector at 100% Utilization
6+ (long term)	Long term parking, overnight parking	12+ amps
3-5 (medium term)	Workplace, hospitality	24+ amps
1-2 (short term)	Shopping and dining	32+ amps

 **NOTE:** 100% utilization represents the worst case scenario for charging speeds, where the least amount of power would be available for each individual vehicle. In most situations, not all Wall Connectors would be actively charging a vehicle, which enables faster charging for the remaining vehicles.

Setting Up Group power management

Group power management is a firmware feature that allows up to six Gen 3 Wall Connectors to limit their total grid current draw to a specified maximum current. This enables more connector installations and higher charging throughput by allowing individual Wall Connectors to be installed at their full current branch circuit capability, while setting a total allocated current so that the electrical service is not overloaded.



Firmware

Wall Connector firmware version **21.18.0 or higher** is required for Group power management operation. Connecting a Wall Connector to local Wi-Fi will allow for automatic firmware updates.

Terms

Table 5.

Group power management network	A set number of Gen 3 Wall Connectors commissioned for wireless communication. A group power management network shall consist of one Leader and multiple Follower Wall Connectors.
Leader	Refers to the Wall Connector unit that is set up as the sole controller of current allocation in a group power management network. Acts as the primary controller of Follower Wall Connectors.
Follower	A Wall Connector under the control of a Leader.
Network Limit	The maximum total current a group power management network is allowed to consume in amps.
Network Current	The sum total current of all Wall Connectors set up in a group power management network, in amps.
Network Size	The total number of Wall Connectors configured in a group power management network.
Fallback (Fair) Limit	The maximum safe fallback current for a unit if communication is lost. Equal to (network limit) / (network size) bounded to within a single unit's capability.
Pilot Current	The current limit advertised to a connected vehicle by a single Wall Connector in amps.
Vehicle Current	The actual measured current consumption of a vehicle connected to a Wall Connector in amps.
Branch Circuit	The circuit conductors between the final overcurrent device protecting the circuit and the Wall Connector.
Shared Panel	A load center with multiple Wall Connector branch circuits, in addition to other unrelated electrical loads.
Dedicated EV Panel	A load center which is fully dedicated to Tesla Wall Connectors installed for group power management.

Installation Options

Electric vehicle branch circuits can be installed in shared panels or dedicated EV panels.



Table 6.

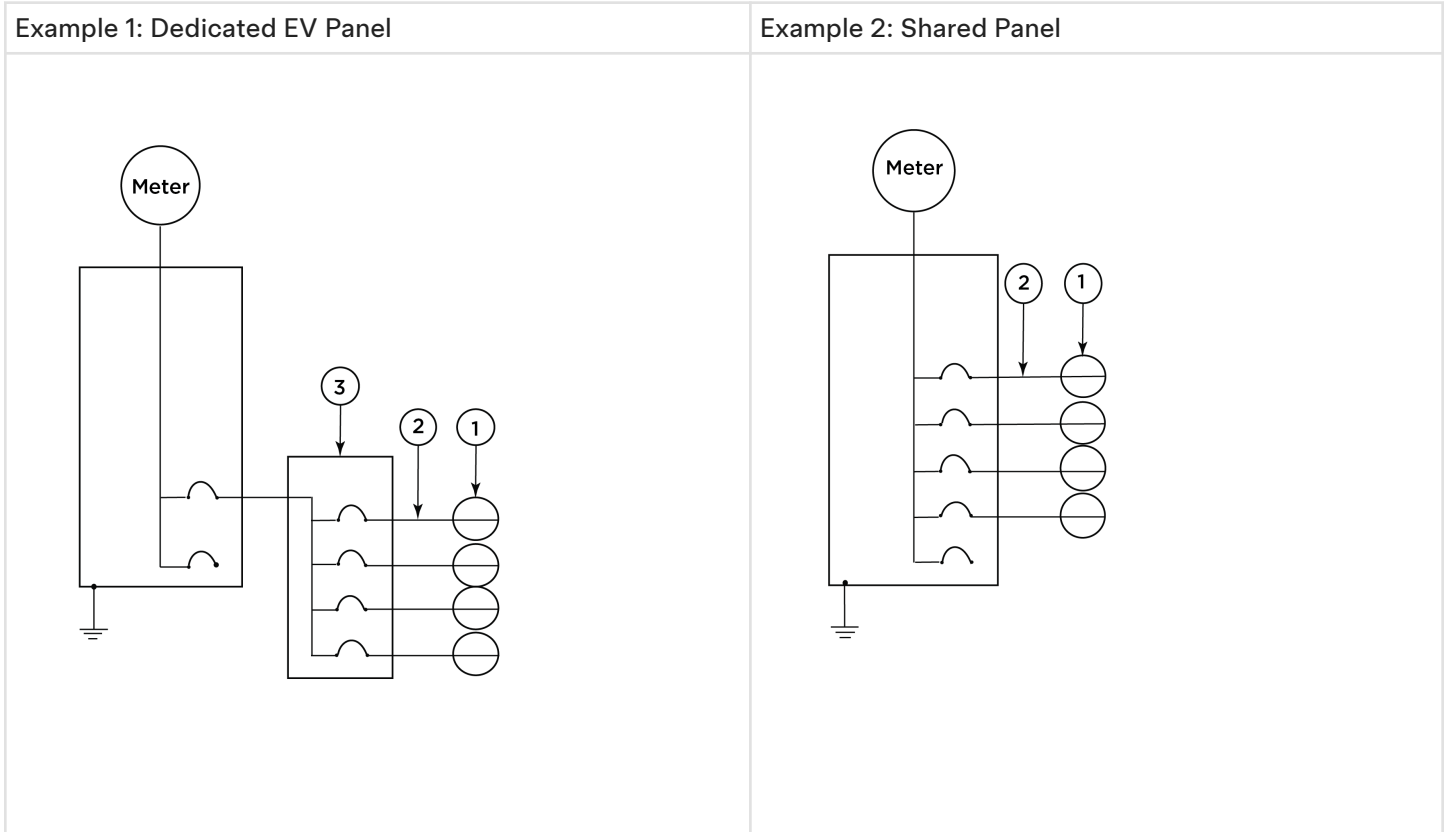

Setup Instructions - Order of Operations

1. Confirm each Wall Connector has firmware version 21.18.0 or higher to enable group power management. In the Wall Connector Commissioning wizard, this can be found under the 'Software' card.



NOTE: When connecting to multiple wall connector, disable the auto-join network feature to ensure that your device does not re-join a Wall Connector you are no longer working on.

2. Once firmware version is confirmed, in the 'Installation' card of the commissioning wizard, set the country and power level for each Wall Connector. It is recommended to install each at the max circuit capacity; however, the branch circuit can be set to a lower output.
3. Designate a leader Wall Connector and add its follower units - see next page for more details.
4. Tap the 'Enabled' button on the leaders group power management configuration page.
5. Connect the leader Wall Connector to the local Wi-Fi network, the leader in a group power management network will share the Wi-Fi credentials with the follower units.

Group Power Management Commissioning

To begin, connect to the Commissioning Wizard for one of the Wall Connectors. This Wall Connector will become the "leader" unit and will be responsible for communicating available amperage to the network.

1. Select **Power Sharing** from the Commissioning Wizard:



GROUP POWER MANAGEMENT



Wall Connector B7S20342Y00519

Standby
Ready to plug in

System Details

Installation Settings ✓ >
48A Max Output Current

Meter >

Wi-Fi Home ✓ >

Access Control >
All Vehicles

Power Sharing >

Software Update >
23.24.3

2. Select **Add Follower** to begin pairing process:



GROUP POWER MANAGEMENT

< Power Sharing

Power Sharing Off

i Power Sharing not configured
Add one or more followers to enable Power Sharing. You can add up to 5 Wall Connectors.

Followers 0/5

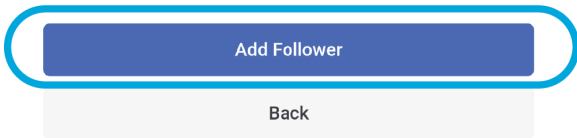

1. Follow on screen instructions to add a second Wall Connector by either scanning QR code from Quick Start Guide or manually entering the SSID and WPA2 info:

SCAN QR CODE	ENTER MANUALLY
<p>Locate Quick Start guide of the Wall Connector you want to add to the network</p> 	<p>Input SSID and WPA2 info from the Wall Connector you want to add to the network</p> <div data-bbox="954 1539 1338 1898"><p>NETWORK (SSID)</p><p>TeslaWallConnector_</p><p>Complete the last 6 characters of the Wi-Fi network name (SSID).</p><p>WPA2 PASSWORD</p><p>Enter the 12-character WPA2 WiFi password.</p><p>CONNECT</p></div>



GROUP POWER MANAGEMENT



NOTE: The Wall Connector you are *adding* must broadcast its own Wi-Fi SSID signal. Press and hold the handle button for 5 seconds.

2. Repeat process to add more Wall Connectors to the network. All added Wall Connectors become followers in the network.
3. Select "Power Sharing Settings" to program a network limit.

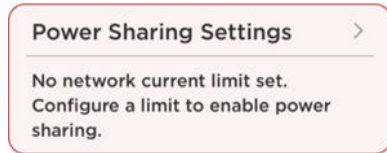

4. In the field, input the network limit:

MAX NETWORK CURRENT (A)

Enter the total current available for the power sharing network. A minimum of 6A per Wall Connector is required.

- 5.



NOTE: This is the maximum total current a group power management network is allowed to consume in amps. This represents the continuous current which the network will not exceed. An electrician will need to determine the correct amount of amperage and confirm that the load center has appropriate overcurrent protection

Expected Behaviors

- SSID access point of all Wall Connectors in a group power management network will continue to broadcast.
- Removing a Wall Connector from a network will temporarily set that device's max output to 6 amps. Cycle circuit breaker to reset Wall Connector to original configuration setting.
- Leader Wall Connector will share site Wi-Fi with follower Wall Connectors.



How to View Existing Group Power Management Networks

Table 7.

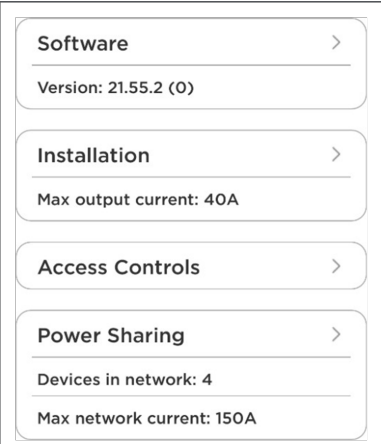
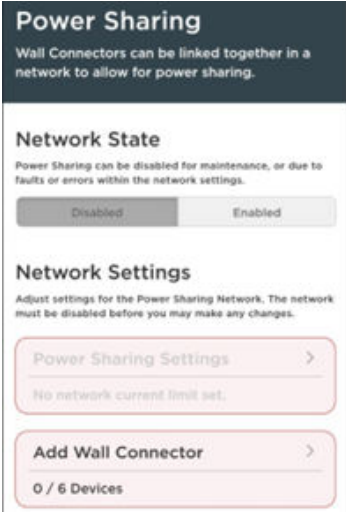
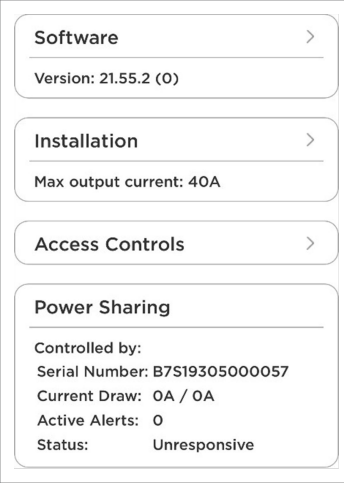
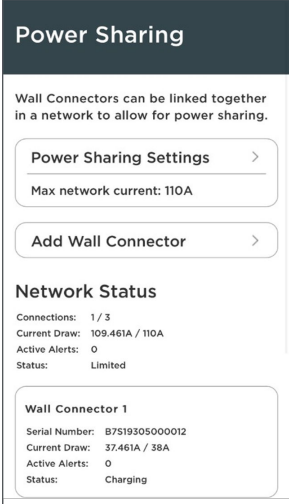
Leader Home Page	Leader Settings Page
 <p>Software > Version: 21.55.2 (0)</p> <p>Installation > Max output current: 40A</p> <p>Access Controls ></p> <p>Power Sharing > Devices in network: 4 Max network current: 150A</p>	 <p>Power Sharing Wall Connectors can be linked together in a network to allow for power sharing.</p> <p>Network State Power Sharing can be disabled for maintenance, or due to faults or errors within the network settings. [Disabled] [Enabled]</p> <p>Network Settings Adjust settings for the Power Sharing Network. The network must be disabled before you may make any changes.</p> <p>Power Sharing Settings > No network current limit set.</p> <p>Add Wall Connector > 0 / 6 Devices</p>
Follower Home Page	Follower Settings Page
 <p>Software > Version: 21.55.2 (0)</p> <p>Installation > Max output current: 40A</p> <p>Access Controls ></p> <p>Power Sharing Controlled by: Serial Number: B7S19305000057 Current Draw: 0A / 0A Active Alerts: 0 Status: Unresponsive</p>	 <p>Power Sharing Wall Connectors can be linked together in a network to allow for power sharing.</p> <p>Power Sharing Settings > Max network current: 110A</p> <p>Add Wall Connector ></p> <p>Network Status Connections: 1 / 3 Current Draw: 109.461A / 110A Active Alerts: 0 Status: Limited</p> <p>Wall Connector 1 Serial Number: B7S19305000012 Current Draw: 37.461A / 38A Active Alerts: 0 Status: Charging</p>



ENABLING COMMERCIAL CHARGING FEATURES

Set Up Commercial Charging capabilities for Wall Connector: <https://www.tesla.com/support/charging/commercial>

- Generate revenue from pay-per-use charging
- Attract residents, renters and guests, or increase traffic to your business
- Monitor live charger statuses and usage reports
- Optional inclusion on Tesla's Find Us page and in-vehicle map for eligible charging sites



WALL CONNECTOR LEDS

Light Codes

Startup

Once energized at the circuit breaker, every LED (seven total) on the faceplate will illuminate for up to five seconds.



After Startup

After Wall Connector is energized at the circuit breaker, certain green LEDs (depending on the circuit breaker size) will illuminate for 10 seconds. See table below for exact light codes.

Circuit breaker	60 A	50 A	40 A	30 A	20 A	15 A
Maximum output	48 A	40 A	32 A	24 A	16 A	12 A

NOTE: To re-display the green LEDs after the initial 10 seconds, press and hold the charging handle button.

When multiple Wall Connectors are linked for group power management, the **center blue LED** will illuminate during the 10-second startup window.

Other

Standby, waiting to plug in	Charging in progress	SSID broadcasting, ready to commission	Waiting to charge, communicating with vehicle
Top green solid	Every green streaming	Green pulsing	Blue solid



Fault Codes

All red blink codes pause for one second, and then repeat.		
Light Bar	What It Means	Details
No Lights	Power supply issue, charging disabled	Verify that the power supply is turned on. If the issue persists, have an electrician remove the Wall Connector from the wirebox and confirm that voltage is present at the terminal block using a multimeter. Record the voltage readings for the following: L1 to L2/N, L1 to Ground, L2/N to Ground.
Solid red	Internal fault, charging disabled	Turn the circuit breaker off, wait 5 seconds, and turn it back on. If solid red light remains, document part number and serial number, then contact Tesla Energy.
One (1) red blink	Ground fault circuit interruption due to unsafe current path, charging disabled	Inspect the handle, cable, Wall Connector, and vehicle charge port for damage or signs of water ingress. Have an electrician check that ground is not directly connected to a conductor wire in the branch circuit.
Two (2) red blinks	Ground assurance fault, high ground resistance detected, charging disabled	Verify that the Wall Connector is properly grounded. The ground connection must be bonded in the upstream power supply for proper operation. Check all physical connections, including the wirebox terminals, electrical panel(s), and junction boxes. In residential power supplies, check the bond between ground and neutral at the main panel. If connected to a step-down transformer, contact the transformer's manufacturer for direction on how to bond the ground connection.
Three (3) red blinks	High temperature detected; charging limited or disabled	Verify that Wall Connector is connected to Wi-Fi and updated with the latest available firmware for optimal temperature sensing functionality. Check the faceplate and cable handle for excessive warmth. Have an electrician remove the Wall Connector from the wirebox and verify that the conductors used are sized correctly and that the terminal block is torqued to specification. Connect Wall Connector to Wi-Fi so that firmware can update to most recent version. If firmware does not automatically update, use the Commissioning Procedure on page 30 to sign into the commissioning wizard and manually update the firmware. If it does not solve the problem, contact our Customer Support team.
Six (6) red blinks	Overvoltage or poor grid quality detected, charging disabled	Verify that the power supply is nominal 200-240 volts. If the issue persists, have an electrician remove the Wall Connector from the wirebox and confirm that voltage readings are as expected at the terminal block using a multimeter. Record the voltage readings for the following: L1 to L2/N, L1 to Ground, L2/N to Ground.
Seven (7) red blinks	Vehicle overcurrent detected	Reduce the vehicle's charge current setting. If the issue persists and the attached vehicle is manufactured by Tesla, record the vehicle's VIN and approximate time of the fault and contact Tesla. If the vehicle is not manufactured by Tesla, contact the vehicle's manufacturer.



Electric Vehicle Service Equipment (EVSE) Communication Codes

Light Bar	Meaning	Details
Solid blue	Connected to Vehicle, Electric Vehicle Service Equipment ready but vehicle not requesting charge	Verify vehicle is ready to charge and not blocked by settings like scheduled charging
Blue "breathing"	Establishing communications with vehicle	
Two (2) blue blinks	Connected to Vehicle, Electric Vehicle Service Equipment not ready to charge	Verify device configuration to ensure settings like scheduled charging, Open Charge Point Protocol, or access control are not preventing charging



TORQUE SPECIFICATIONS

Table 8. Torque Specifications

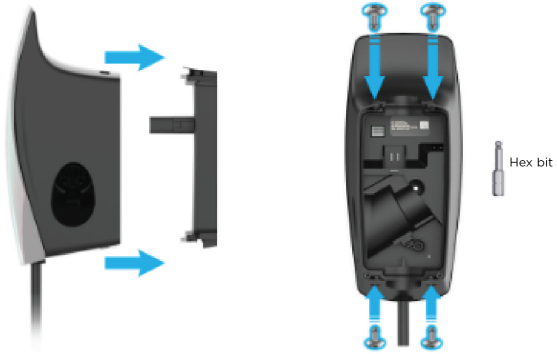
	Component	Specification
Electrical Terminations		strip to 13 mm (½ in)
Terminal Connections		50 in lb (5.6 Nm)
M4 screws (x4)		N/A



WARRANTY INFORMATION

Subject to the exclusions and limitations described below, this Charging Equipment Limited Warranty covers the refund, repair or replacement necessary to remedy any manufacturing defects in a Tesla manufactured and supplied Wall Connector (including any Tesla Remote Meter as an accessory for Wall Connector to enable dynamic power management) that occur under normal personal use for a period of 48 months, or a period of 12 months for normal commercial use*, and a Tesla manufactured and supplied Mobile Connector or charging adapter that occur under normal use for a period of 12 months, starting from the date of invoice to the customer for any charging equipment. Any Tesla manufactured and supplied connector or adapter included in the initial purchase and delivery of a Tesla vehicle by Tesla is covered under the Basic Vehicle Limited Warranty section of the New Vehicle Limited Warranty for 4 years or 50,000 miles (80,000 km), whichever comes first, subject to the terms and conditions of the New Vehicle Limited Warranty.

*For warranty claims specific to Wall Connectors (including any Tesla Remote Meter accessories), "commercial use" means Wall Connectors (and, if applicable, any Tesla Remote Meter accessories) used for purposes other than charging at a residential single family home for daily personal use, which includes, but is not limited to, charging at hotels, offices, parking lots and complexes (including apartment, condominiums and other multi-family or unit dwellings), and retail and other locations that allow (including by being listed online or publicly) for pay-for-use charging, or are located where users other than the owner could reasonably obtain access to the Wall Connector.

This Charging Equipment Limited Warranty does not cover any damage or malfunction directly or indirectly caused by, due to, or resulting from, normal wear or deterioration, abuse, misuse, negligence, accident, lack of or improper installation, use, maintenance, storage or transport, including, but not limited to, any of the following:

Failure to follow the instructions, operation, maintenance and warnings published in the documentation supplied with your Tesla connector or adapter;

External factors, including but not limited to, objects striking the Tesla connector or adapter, faulty or damaged electrical wiring or connections, external electrical faults, junction boxes, circuit breakers, receptacles or power outlets, the environment or an act of God, including, but not limited to, fire, earthquake, water, lightning and other environmental conditions;

General appearance or damage to paint, including chips, scratches, dents and cracks;

Failure to contact Tesla upon discovery of a defect covered by this Charging Equipment Limited Warranty;

Any repair, alteration or modification to the Tesla connector or adapter or any part, or the installation or use of any parts or accessories, made by a person or facility not authorized or certified to do so; and

Lack of or improper installation, repair or maintenance, including use of non-genuine Tesla accessories or parts.

Although Tesla does not require you to perform all maintenance, service or repairs at a Tesla Service Center or Tesla authorized repair facility, this Charging Equipment Limited Warranty may be voided, or coverage may be excluded, due to lack of or improper maintenance, service or repairs. Tesla Service Centers and Tesla authorized repair facilities have special training, expertise, tools and supplies with respect to Tesla connectors and adapters and, in certain cases, may employ the only persons, or be the only facilities authorized or certified to work on Tesla connectors and adapters. Tesla strongly recommends that you have all maintenance, service and repairs done at a Tesla Service Center or Tesla authorized repair facility in order to avoid voiding, or having coverage excluded under, this Charging Equipment Limited Warranty.



Limits of Liability

This Charging Equipment Limited Warranty is the only express warranty made in connection with your Tesla connector or adapter. Implied and express warranties and conditions arising under applicable local laws, federal statute or otherwise, in law or in equity, if any, including, but not limited to, implied warranties and conditions of merchantability or merchantable quality, fitness for a particular purpose, durability, or those arising by a course of dealing or usage of trade, or any warranties against latent or hidden defects, are disclaimed to the fullest extent allowable by your local law, or limited in duration to the term of this Charging Equipment Limited Warranty. To the fullest extent allowable by your local law, the performance of necessary repairs and/or replacement of new, reconditioned, or remanufactured parts by Tesla for the covered defects is the exclusive remedy under this Charging Equipment Limited Warranty or any implied warranties. To the maximum extent permissible under your local law, liability is limited to the reasonable price for repair or replacement of the applicable Tesla connector or adapter, not to exceed the manufacturer's suggested retail price. Replacement may be made with parts of like kind and quality, including non-original manufacturer's parts, or reconditioned or remanufactured parts, as necessary. This Charging Equipment Limited Warranty covers only parts and factory labor necessary to repair but does not include any on-site labor costs related to un-installing, reinstalling or removing the repaired or replacement charging equipment. Parts repaired or replaced, including replacement of a Tesla connector or adapter, under this Charging Equipment Limited Warranty are covered only until the applicable warranty period of this Charging Equipment Limited Warranty ends, or as otherwise provided by applicable law. Under no circumstances will the original warranty period be extended as a result of your Tesla connector or adapter being repaired or replaced.

Tesla shall not be liable for any defects under this Charging Equipment Limited Warranty that exceed the fair market value of the applicable Tesla connector or adapter at the time immediately preceding the discovery of the defect. In addition, the sum of all benefits payable under this Charging Equipment Limited Warranty shall not exceed the price you paid for the applicable Tesla connector or adapter.

Tesla does not authorize any person or entity to create for it any other obligations or liability in connection with this Charging Equipment Limited Warranty. Subject to local laws and regulations, the decision of whether to repair or replace a part or to use a new, reconditioned or remanufactured part will be made by Tesla, in its sole discretion. Tesla may occasionally offer to pay some or all of the cost of certain repairs that are not covered by this Charging Equipment Limited Warranty, either for specific models or on an ad hoc, case-by-case basis. Tesla reserves the right to do the above at any time without incurring any obligation to make a similar payment to other Tesla charging equipment owners.

To the maximum extent permissible under local law, Tesla hereby disclaims any and all indirect, incidental, special and consequential damages arising out of, or relating to, the Tesla connector or adapter, including, but not limited to, transportation to and from a Tesla Authorized Service Center, loss of the Tesla connector or adapter, loss of vehicle value, loss of time, loss of income, loss of use, loss of personal or commercial property, inconvenience or aggravation, emotional distress or harm, commercial loss (including but not limited to lost profits or earnings), towing charges, bus fares, vehicle rental, service call charges, gasoline expenses, lodging expenses, damage to tow vehicle, and incidental charges such as telephone calls, facsimile transmissions, and mailing expenses.

The above limitations and exclusions shall apply whether your claim is in contract, tort (including negligence and gross negligence), breach of warranty or condition, misrepresentation (whether negligent or otherwise), or otherwise at law or in equity, even if Tesla is advised of the possibility of such damages or such damages are reasonably foreseeable.

Nothing in this Charging Equipment Limited Warranty shall exclude, or in any way limit, Tesla's liability for death or personal injury solely and directly caused by Tesla's negligence, or that of its employees, agents or sub-contractors (as applicable), fraud or fraudulent misrepresentation, or any other liability to the extent the same is proven in a court of competent jurisdiction in a final nonappealable judgment and may not be excluded or limited as a matter of local law.



WARRANTY INFORMATION

Dispute Resolution

To the fullest extent allowed by local law, Tesla requires that you first provide written notification of any manufacturing defect within a reasonable time, and within the applicable coverage period specified in this Charging Equipment Limited Warranty, and allow Tesla an opportunity to make any needed repairs before submitting a dispute to our dispute settlement program (described below). Please send written notification on dispute resolution to the following address:

Vehicles registered in the U.S.:

Tesla, Inc

3500 Deer Creek Road

Palo Alto, California

Attention: Charging Equipment Warranty Claims

Phone number: 1-877-79-TESLA (1-877-798-3752)

Please include the following information:

- Tesla connector or adapter invoice date
- Your name and contact information
- Name and location of the Tesla Store and/or Tesla Service Center nearest to you
- Description of the defect
- History of the attempts you have made with Tesla to resolve the concern, or of any repairs or services that were not performed by Tesla
- In the event any disputes, differences, or controversies arise between you and Tesla related to this Charging Equipment Limited Warranty, Tesla will explore all possibilities for an amicable settlement

Agreement to Arbitrate

Please carefully read this provision, which applies to any dispute between you and Tesla, Inc. and its affiliates (together "Tesla").

If you have a concern or dispute, please send a written notice describing it and your desired resolution to resolutions@tesla.com.

If not resolved within 60 days, you agree that any dispute arising out of or relating to any aspect of the relationship between you and Tesla will not be decided by a judge or jury but instead by a single arbitrator in an arbitration administered by the American Arbitration Association (AAA) under its Consumer Arbitration Rules. This includes claims arising before this Charging Equipment Limited Warranty, such as claims related to statements about our products.

Tesla will pay all AAA fees for any arbitration, which will be held in the city or county of your residence. To learn more about the Rules and how to begin an arbitration, you may call any AAA office or go to www.adr.org.

The arbitrator may only resolve disputes between you and Tesla and may not consolidate claims without the consent of all parties. The arbitrator cannot hear class or representative claims or requests for relief on behalf of others purchasing or leasing Tesla products. In other words, you and Tesla may bring claims against the other only in your or its individual capacity and not as a plaintiff or class member in any class or representative action. If a court or arbitrator decides that any part of this agreement to arbitrate cannot be enforced as to a particular claim for relief or remedy (such as injunctive or declaratory relief), then that claim or remedy (and only that claim or remedy) shall be severed and must be brought in court and any other claims must be arbitrated.



WARRANTY INFORMATION

If you prefer, you may instead take an individual dispute to small claims court.

You may opt out of arbitration within 30 days after signing this Charging Equipment Limited Warranty by sending a letter to: Tesla, Inc.; P.O. Box 15430; Fremont, CA 94539-7970, stating your name, product, and intent to opt out of the arbitration provision. If you do not opt out, this agreement to arbitrate overrides any different arbitration agreement between us, including any arbitration agreement in a lease or finance contract.



APPENDIX A: DAISY CHAINING MULTIPLE WALL CONNECTORS

Daisy Chaining Multiple Wall Connectors

Tesla recommends daisy chaining Wall Connectors at sites with more than two Wall Connectors to improve installation costs wherever full power is not always needed. Implementing this installation process leads to simplification of site design, fewer materials used, and overall reduced costs. This is particularly effective whenever two Wall Connectors are mounted on a single pedestal or next to each other on a wall.

The Universal Wall Connector supports daisy chaining of multiple Wall Connectors on a single branch circuit by feeding additional Wall Connectors from the second set of terminals. In this arrangement, the wire box of a Wall Connector can be used as a pass-through supply to the subsequent Wall Connector. Daisy chaining is currently only supported on the Universal Wall Connector.

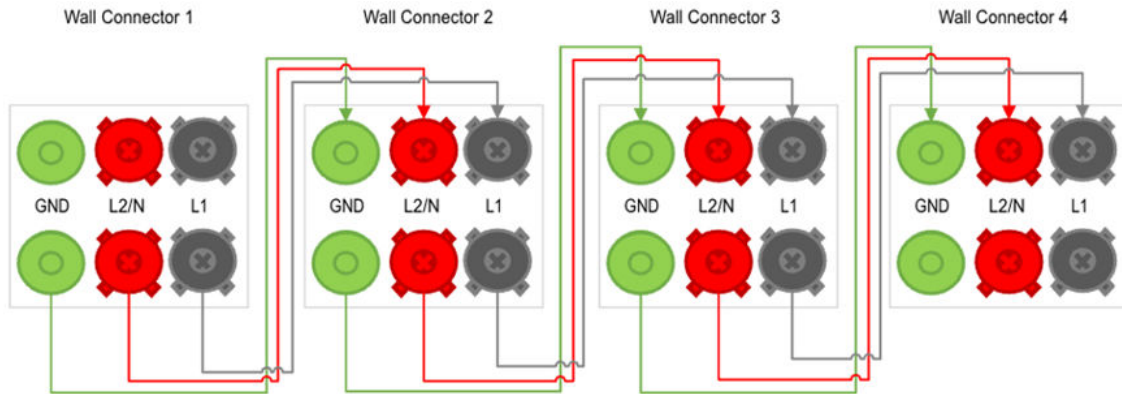

The maximum current rating for a daisy chain is 48A, fed by a 60A circuit breaker. All Wall Connectors in a daisy chain must be configured as a single group power management unit with a network limit of no more than 48A. The current rating can be configured in the Tesla One app during the [Commissioning Process on page 30](#).

APPENDIX A: DAISY CHAINING MULTIPLE WALL CONNECTORS

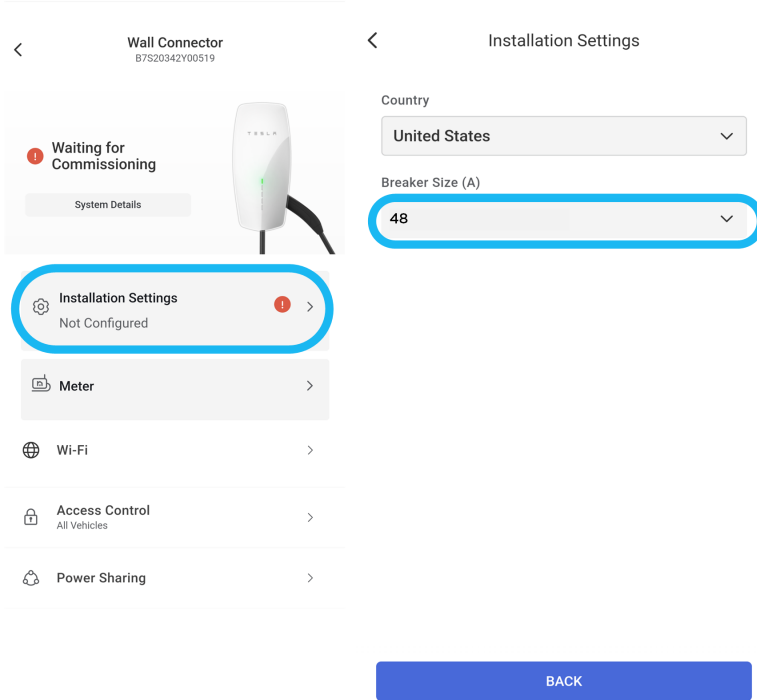

All power conductors in the daisy chain must also be sized to carry the full network limit current. For example, if the group power management unit current limit is set to 48A, all conductors in the daisy chain must be sized for 48A continuous.

The number of Wall Connectors in a daisy chain should be selected to ensure any minimum required power levels are maintained. Available current is redistributed equally among all connected vehicles whenever a new vehicle is plugged or unplugged from a connector.

Table 9.

	1 Wall Connector		2 Daisy chained Wall Connectors		3 Daisy Chained Wall Connectors		4 Daisy Chained Wall Connectors	
	240V	208V	240V	208V	240V	208V	240V	208V
48A	11.5 kW	9.9 kW	5.7 kW	4.9 kW	3.8 kW	3.2 kW	2.9 kW	2.5 kW
32 A Group Limit	7.9 kW	6.7 kW	3.8 kW	3.3 kW	2.5 kW	2.2 kW	Not Recommended	
24 A Group Limit	5.7 kW	4.9 kW	2.9 kW	2.5 kW	Not Recommended		Not Recommended	

Each Universal Wall Connector has three bi-directional terminals in the wirebox: L1, L2, and GND. Form a daisy-chained network by connecting the cables from each terminal of the Wall Connector to the corresponding terminal of another wall connector as shown below.



APPENDIX A: DAISY CHAINING MULTIPLE WALL CONNECTORS

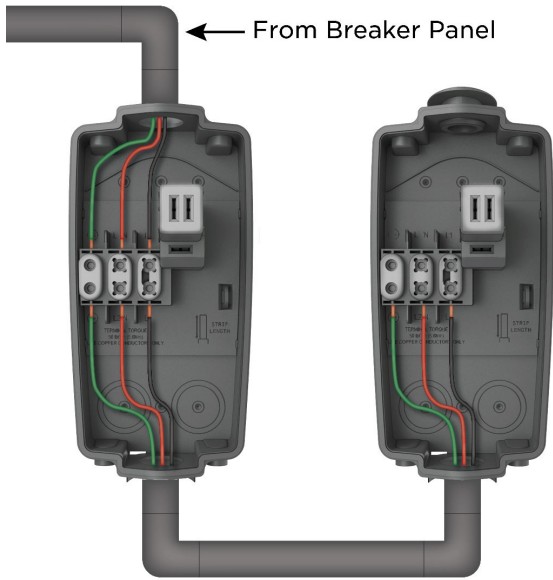

Planning the installation:

- Choose a breaker appropriate for the location and circuit size.
- Choose the right amperage based on the application of the site.
- See the recommended amperage based on the power output and the application of the site.

Table 10.

Expected Park Time (hours)	Examples	Minimum amperage per wall connector at 100% utilization	Power output at 240 volts (kW)	Power output at 208 volts (kW)
>8+	Overnight parking, airport	12 A min	2.75 kW	2.4 kW
4-8	Long term parking, overnight parking	24 A min	5.7 kW	4.9 kW
	Workplace, hospitality			
1-3	Shopping and dining	48 A min	11.5 kW	10 kW

For a 6 Wall Connector site, a 225 A breaker panel is preferred. For a single-phase implementation, see figure below. For a 12 Wall Connector site, a 400 A breaker panel is preferred.

APPENDIX A: DAISY CHAINING MULTIPLE WALL CONNECTORS

6 Wall Connector Daisy Chained
3 pairs

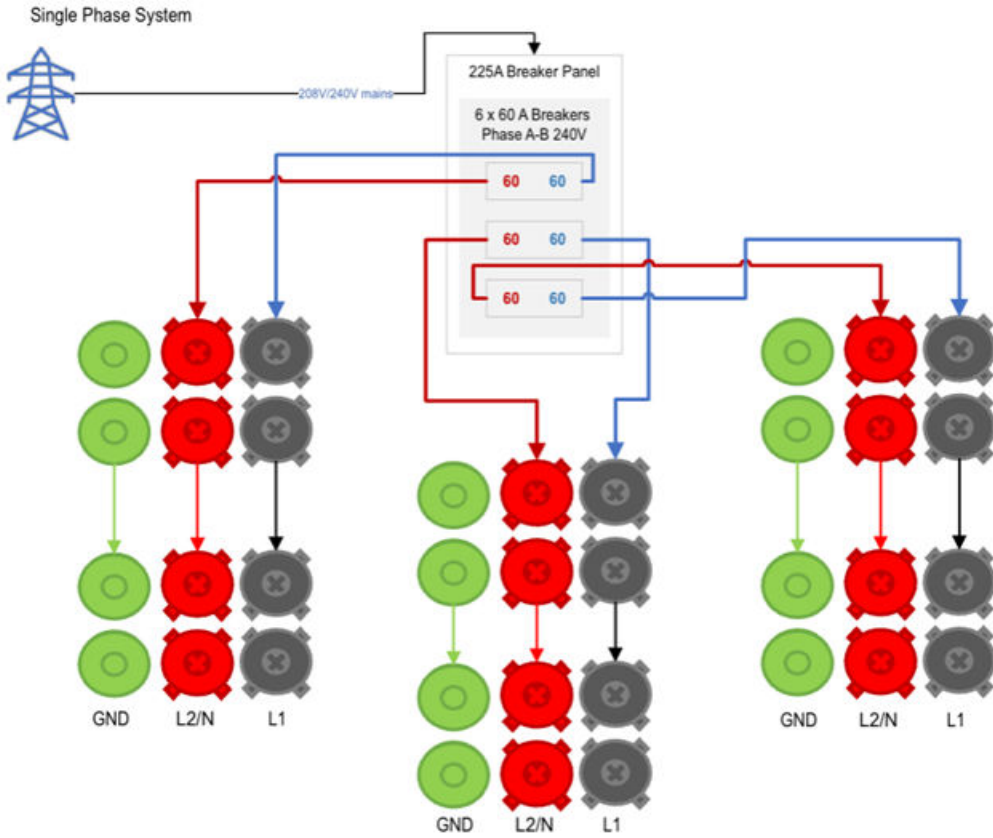

To implement daisy chaining in a three-phase system, daisy-chained groups of Wall Connectors should be distributed as evenly as possible among phase pairs as shown in the figure below.



APPENDIX A: DAISY CHAINING MULTIPLE WALL CONNECTORS

6 Wall Connector Daisy Chained
3 pairs
3-Phase System

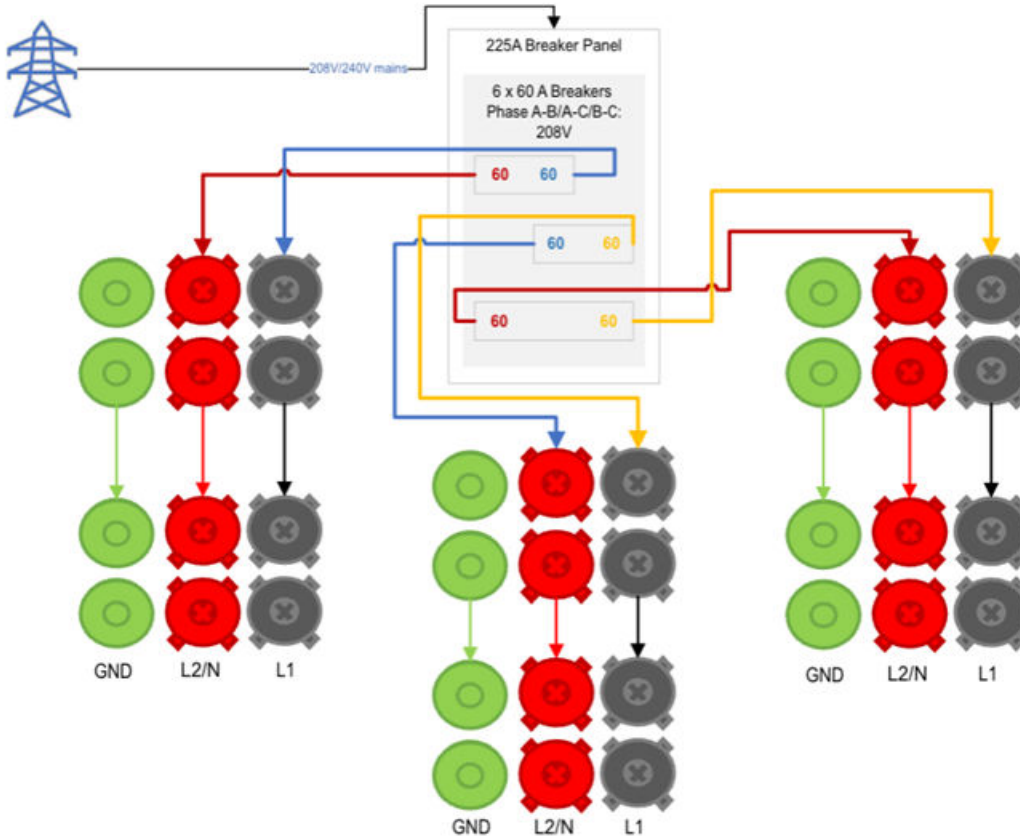

Examples of Daisy Chain Using a Pedestal

If the Wall Connectors are mounted on a pedestal, drill two openings at the rear entry locations with a 1-1/8 in (29 mm) step bit. Route the wiring through these openings and through the pedestal to make the connections.

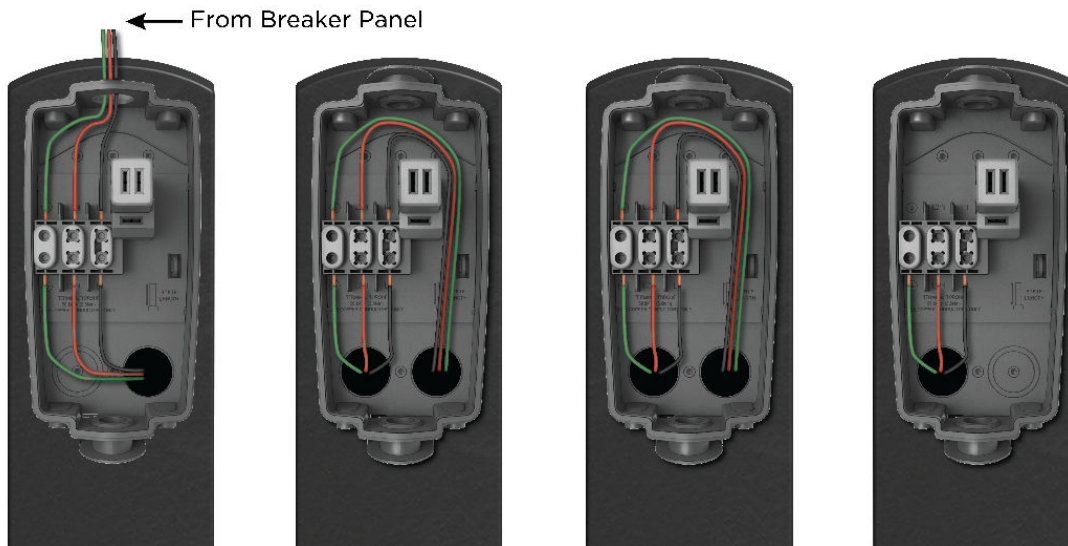

Examples of Daisy Chain on a Wall Mounted Site

If the Wall Connectors are mounted on a wall, you can utilize either the top or bottom openings and route the wires through a 1-inch conduit.

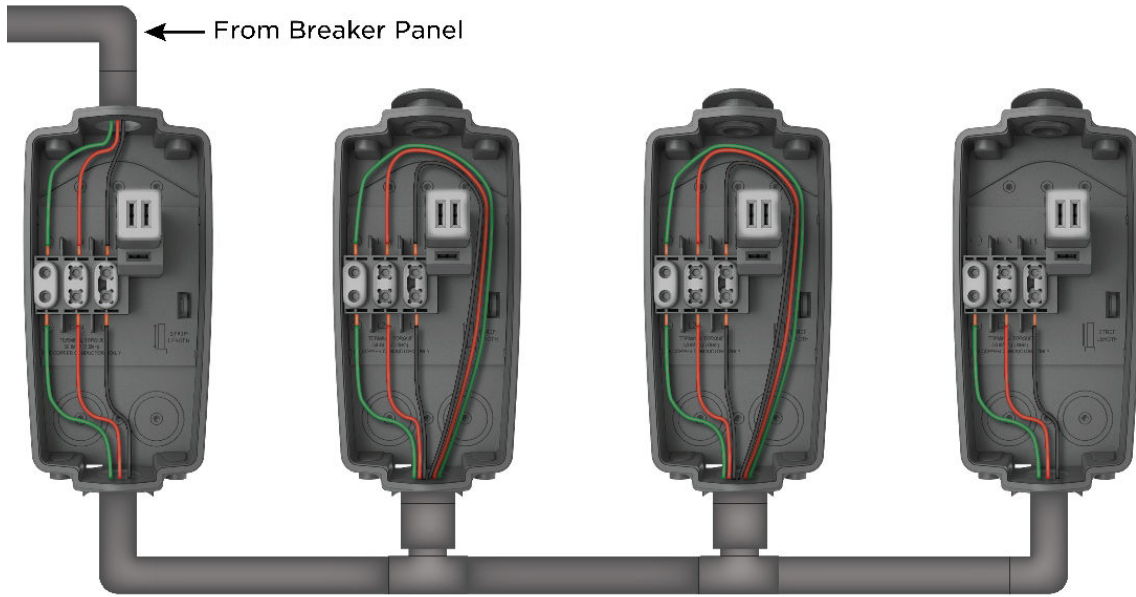

TESLA

Revision 1.0